



**PSEN op2B/1 Series**

PSEN sensor technology

**PILZ**  
THE SPIRIT OF SAFETY

This document is a translation of the original document.

All rights to this documentation are reserved by Pilz GmbH & Co. KG. Copies may be made for internal purposes. Suggestions and comments for improving this documentation will be gratefully received.

Pilz®, PIT®, PMI®, PNOZ®, Primo®, PSEN®, PSS®, PVIS®, SafetyBUS p®, SafetyEYE®, SafetyNET p®, the spirit of safety® are registered and protected trademarks of Pilz GmbH & Co. KG in some countries.



SD means Secure Digital

<b>Section 1</b>	<b>Introduction</b>	<b>6</b>
	1.1 Validity of documentation	6
	1.2 Using the documentation	6
	1.3 Definition of symbols	6
<b>Section 2</b>	<b>Overview</b>	<b>8</b>
	2.1 Product types	8
	2.2 Unit features	8
	2.3 Types	9
	2.3.1 Safety light grid without integrated muting sensors	9
	2.3.2 Expansion for muting in one direction	9
	2.3.3 Expansion for muting in two directions	10
	2.4 Scope	10
<b>Section 3</b>	<b>Safety</b>	<b>11</b>
	3.1 Intended use	11
	3.2 Safety regulations	11
	3.2.1 Safety assessment	11
	3.2.2 Use of qualified personnel	12
	3.2.3 Warranty and liability	12
	3.2.4 Disposal	12
<b>Section 4</b>	<b>Function description</b>	<b>13</b>
	4.1 Basic function	13
	4.1.1 Function settings when delivered	14
	4.2 Restart after unit is triggered	14
	4.3 Reset function	15
	4.4 EDM	16
	4.5 Muting	17
	4.5.1 Technical implementation	19
	4.5.2 Time monitoring - Timeout	22
	4.6 Override	23
	4.7 Test function	24
	4.8 Convert type without muting set to L/T-type	25
<b>Section 5</b>	<b>Project configuration</b>	<b>26</b>
	5.1 Maintaining the safety distance	26
	5.2 Ambient conditions	26
	5.3 Distance from reflective surfaces	27
	5.4 Installation of several adjacent safety light grids	28
	5.5 Use of deviating mirrors	29
	5.6 Use of the muting function	31
<b>Section 6</b>	<b>Installation and wiring</b>	<b>35</b>
	6.1 Attach safety light grid without muting sensors to mounting surface	35
	6.2 Conversion of safety light grids without muting sensors	35
	6.3 Installation of external muting sensors	36

6.4	Wiring	37
6.4.1	General guidelines	37
6.4.2	Connector pin assignment	37
6.4.3	TEST/START button	39
6.4.4	EDM	39
6.4.5	Earthing the safety light grid	40
6.4.6	Connections for muting	40
6.4.7	Wiring of external sensors on the safety light grid	41
<b>Section 7</b>	<b>Commissioning</b>	<b>42</b>
7.1	Setting the functions	42
7.1.1	Open DIP switch cover	42
7.1.2	Activate muting	42
7.1.3	Set muting timeout	43
7.1.4	Activate EDM	43
7.1.5	Restart after unit is triggered	43
7.2	Orientation	44
7.2.1	General guidelines	44
7.2.2	Safety light grid alignment	45
7.2.3	Muting sensor alignment	46
7.2.4	LED support during alignment	47
7.3	Checking the safety light grid	47
7.4	System connection	48
<b>Section 8</b>	<b>Operation</b>	<b>49</b>
8.1	Status information during operation	49
8.2	Perform test	50
8.3	Diagnostics and troubleshooting	50
8.3.1	Indicators for fault diagnostics	50
8.3.2	Perform reset	52
<b>Section 9</b>	<b>Regular checks and maintenance</b>	<b>53</b>
9.1	Checks	53
9.1.1	Regular checks	53
9.1.2	Daily check	53
9.1.3	Check after plant/machine modification	53
9.2	Maintenance	53
<b>Section 10</b>	<b>Dimensions</b>	<b>55</b>
<b>Section 11</b>	<b>Technical details</b>	<b>56</b>
11.1	Safety characteristic data	58
<b>Section 12</b>	<b>Order reference</b>	<b>59</b>
12.1	Order reference for safety light grids	59
12.2	Order reference for accessories	59

<b>Section 13</b>	<b>Attachment</b>	<b>62</b>
	13.1 Check list	62

---

# 1 Introduction

## 1.1 Validity of documentation

This documentation is valid for the product PSEN op2B/1 Series. It is valid until new documentation is published.

This operating manual explains the function and operation, describes the installation and provides guidelines on how to connect the product.

## 1.2 Using the documentation

This document is intended for instruction. Only install and commission the product if you have read and understood this document. The document should be retained for future reference.

## 1.3 Definition of symbols

Information that is particularly important is identified as follows:



### **DANGER!**

This warning must be heeded! It warns of a hazardous situation that poses an immediate threat of serious injury and death and indicates preventive measures that can be taken.



### **WARNING!**

This warning must be heeded! It warns of a hazardous situation that could lead to serious injury and death and indicates preventive measures that can be taken.



### **CAUTION!**

This refers to a hazard that can lead to a less serious or minor injury plus material damage, and also provides information on preventive measures that can be taken.



### **NOTICE**

This describes a situation in which the product or devices could be damaged and also provides information on preventive measures that can be taken. It also highlights areas within the text that are of particular importance.

**INFORMATION**

This gives advice on applications and provides information on special features.

## 2 Overview

### 2.1 Product types

Product type	Protected field	
	Max. height in mm	Max. width in m
PSEN op2B-2-050/1	515	50
PSEN op2B-3-080/1	815	50
PSEN op2B-4-090/1	915	50
PSEN op2B-4-120/1	1215	50

#### Height

The height of the protected field describes the effective protected height, in which a matt, opaque object corresponding to the specific resolution will be detected.

#### Width

The maximum width of the protected field is determined by the maximum operating range of the light beam sent from the transmitter to the receiver.

The minimum width of the protected field corresponds to the minimum operating range stated in the [Technical details](#) [ 56].

### 2.2 Unit features

Safety light grids in the PSEN op2B/1 Series are multibeam optoelectronic protective devices for work areas in which

- ▶ machines,
- ▶ robots and
- ▶ automated plants

could endanger the physical integrity of operators.

#### Features of the safety light grid

- ▶ Type 2
- ▶ Safeguards protected fields with body resolution
- ▶ Muting
  - All safety light grids in the PSEN op2B/1 Series are able to process data from connected muting sensors
- ▶ Infrared protected field is generated
- ▶ Transmitter and receiver are synchronised optically
- ▶ Override
- ▶ LED for status information
- ▶ LED for support during alignment

## 2.3 Types

### 2.3.1 Safety light grid without integrated muting sensors

- ▶ Safety light grid with body resolution

The safety light grid is equipped for muting applications. External muting sensors with reflective sensors or with transmitter and receiver sensors can be used for muting applications (see [Order reference for accessories, section on muting accessories](#) [ 60]).

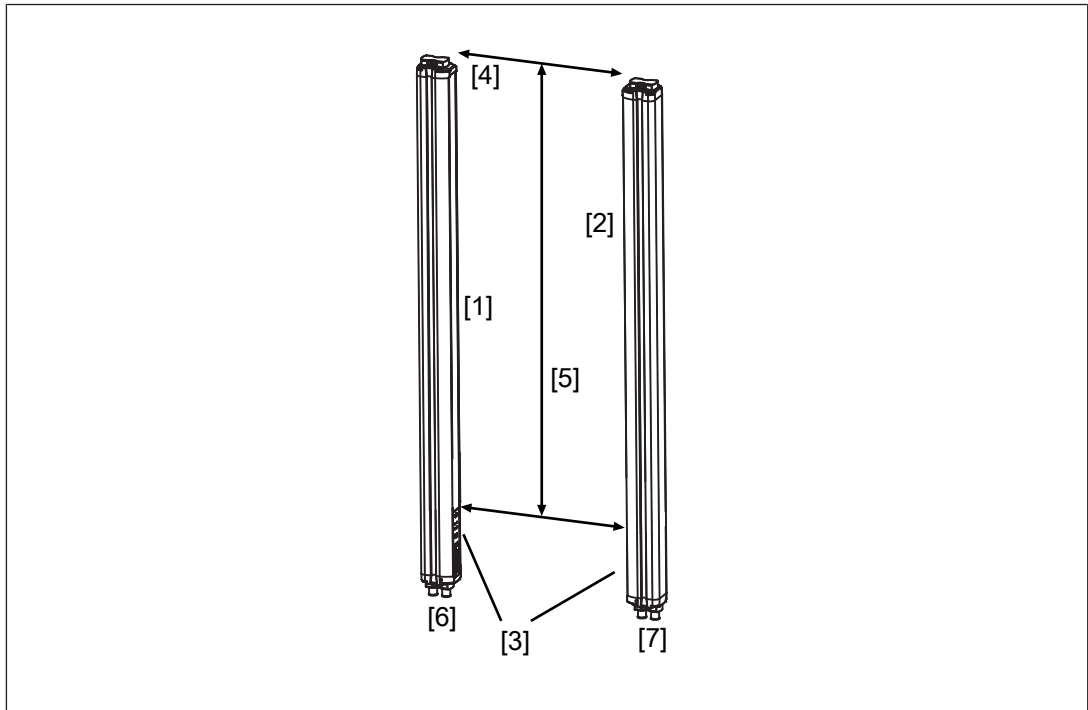

Fig.: View of safety light grid without integrated muting sensors

#### Legende

- [1] Receiver
- [2] Transmitter
- [3] LED on receiver/transmitter
- [4] Height of the protected field
- [5] Width of the protected field
- [6] 8-pin and 5-pin connector of receiver
- [7] 4-pin and 5-pin connector of transmitter

### 2.3.2 Expansion for muting in one direction

Order reference	Description
PSEN op2.1 L-Muting Set	L-muting sensors to retrofit
PSEN op muting bracket kit	Mounting bracket for one muting sensor
PSEN op cable M12 4-p. 0.75m L-muting	Connection cable for L-muting, 4-core, shielded

### 2.3.3 Expansion for muting in two directions

Order reference	Description
PSEN op2.2 T-Muting Set	T-muting sensors to retrofit
PSEN op muting bracket kit	Mounting bracket for one muting sensor
PSEN op cableset	Connection cable for T-muting, 4-core, shielded

## 2.4 Scope

### Safety light grid with body resolution, without integrated muting sensors

Order reference	Description
PSEN op2B-2-050/1 or PSEN op2B-3-080/1 or PSEN op2B-4-090/1 or PSEN op4B-4-120/1	Safety light grid, consisting of <ul style="list-style-type: none"> <li>▶ Transmitter,</li> <li>▶ Receiver</li> <li>▶ Mounting kit</li> </ul>

## 3 Safety

### 3.1 Intended use

Safety light grids in the PSEN op2B/1 Series constitute electrosensitive protective equipment. They are used to protect personnel and plants. The safety light grids are designed to

- ▶ Safeguards protected fields with body resolution
- ▶ Safeguard danger zones and
- ▶ Safeguard access.

The safety light grid may only be used for personal protection on machinery if

- ▶ The hazardous state can be stopped by the safety light grid and/or
- ▶ The machine can be prevented from starting up.

Ensure that the start-up method meets the defined safety requirements.

- ▶ Without restart interlock (status when delivered) or
- ▶ With restart interlock

Intended use includes making the electrical installation EMC-compliant.

The product is designed for use in an industrial environment. Interference may occur if used within a domestic environment.

Before using the safety light grid, check whether the safety light grid's housing material can withstand the chemical substances used in the production process (see [Technical details \[📖 56\]](#)).

The following is deemed **improper** use:

- ▶ Using the safety light grids outdoors
- ▶ Using the safety light grids to protect against flying parts
- ▶ Using the safety light grids in a radioactive environment
- ▶ Using the safety light grids outside the areas described in this manual
- ▶ Using the safety light grids outside the documented [Technical Details \[📖 56\]](#).



#### INFORMATION

Other safety devices and protective measures may be required in addition to the safety light grid. These should be determined via a safety assessment based on the specific application area and specific local conditions (e.g. official specifications).

### 3.2 Safety regulations

#### 3.2.1 Safety assessment

Before using a unit it is necessary to perform a safety assessment in accordance with the Machinery Directive.

Functional safety is guaranteed for the product as a single component. However, this does not guarantee the functional safety of the overall plant/machine. In order to achieve the required safety level for the overall plant/machine, define the safety requirements for the plant/machine and then define how these must be implemented from a technical and organisational standpoint.

### 3.2.2 Use of qualified personnel

The products may only be assembled, installed, programmed, commissioned, operated, maintained and decommissioned by competent persons.

A competent person is someone who, because of their training, experience and current professional activity, has the specialist knowledge required to test, assess and operate the work equipment, devices, systems, plant and machinery in accordance with the general standards and guidelines for safety technology.

It is the company's responsibility only to employ personnel who:

- ▶ Are familiar with the basic regulations concerning health and safety / accident prevention
- ▶ Have read and understood the information provided in this description under "Safety"
- ▶ And have a good knowledge of the generic and specialist standards applicable to the specific application.

### 3.2.3 Warranty and liability

All claims to warranty and liability will be rendered invalid if

- ▶ The product was used contrary to the purpose for which it is intended
- ▶ Damage can be attributed to not having followed the guidelines in the manual
- ▶ Operating personnel are not suitably qualified
- ▶ Any type of modification has been made (e.g. exchanging components on the PCB boards, soldering work etc.).

### 3.2.4 Disposal

- ▶ In safety-related applications, please comply with the mission time  $T_M$  in the safety-related characteristic data.
- ▶ When decommissioning, please comply with local regulations regarding the disposal of electronic devices (e.g. Electrical and Electronic Equipment Act).

## 4 Function description

### 4.1 Basic function

The safety light grid consists of a transmitter and receiver, which are housed in rugged aluminium profiles and therefore protected from external damage.

The protected area is covered by infrared light beams, which are emitted from the transmitter to the receiver. The protected field that is produced is able to detect an opaque object.

As soon as an object or part of the operator's body interrupts the beams sent by the transmitter, the output signal switching device (OSSD) is immediately switched off and the connected machine is stopped immediately as a result. The object or body part must be at least the size of the resolution covered by the safety light grid.

The functions of the safety light grid are set via DIP switches, which are located beneath a flap on the connector side of the safety light grid. The electrical connection is made via an M12 connector, which is positioned underneath the profiles.

The following functions are set via DIP switches:

- ▶ Timeout muting
- ▶ Muting
- ▶ EDM
- ▶ Restart after unit is triggered

The functions



- ▶ Timeout muting and
- ▶ Muting

can only be used if muting sensors are connected to the safety light grid.

The transmitter and receiver are synchronised optically, so the two units do not have to be connected directly to each other.

The infrared beams that are transmitted and received are controlled and monitored via microprocessors, which provide the user with information about the operating state of the safety light grid and the potential error state via LED indicators. During the installation phase, two yellow LEDs simplify the alignment of the two units.

The indicators are described under:

- ▶ [Status information during operation](#)  49]
- ▶ [LED support during alignment](#)  47]
- ▶ Indicators for fault diagnostics

### 4.1.1 Function settings when delivered

The safety light grid is delivered with all DIP switches in the ON position.

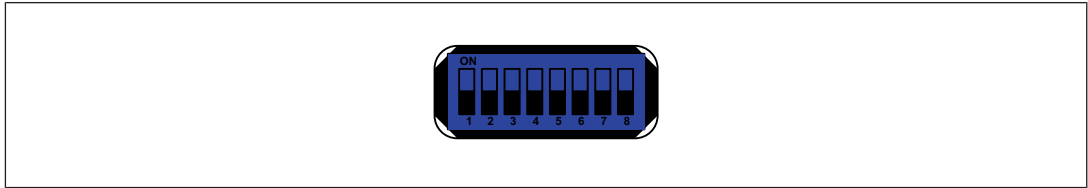

Fig.: DIP switches all ON

As a result the functions are set as follows:

Function	DIP switch	Position	Set function
Timeout muting	1 and 5	ON	10 minutes
Muting	2 and 6	ON	T-configuration (4 beams) or cross muting When using the L-configuration, DIP switches 2 and 6 must be set to OFF.
EDM	3 and 7	ON	Deactivated
Restart interlock	4 and 8	ON	Without restart interlock

Functions can be selected via DIP switch - settings when delivered

## 4.2 Restart after unit is triggered

If the safety light grid has switched off the OSSDs, the connected machine is stopped.

Once the protected field is clear again, the safety light grid must be reset to its normal operating state.

The restart can be achieved in two ways:

- ▶ Without restart interlock (status when delivered)
  - The safety light grid is automatically reset to its normal operating state.
- ▶ With restart interlock
  - The light grid is not reset to its normal operating state until
    - The TEST/START button has been operated for at least 0.5 s and
    - The area of the protected field is clear again and the light beams are no longer interrupted.



#### NOTICE

The machine may only be restarted via a TEST/START button.

It must not be possible to operate the pushbutton from inside the danger zone. The button must be located at a position from which there is a full, unobstructed view of the danger zone.

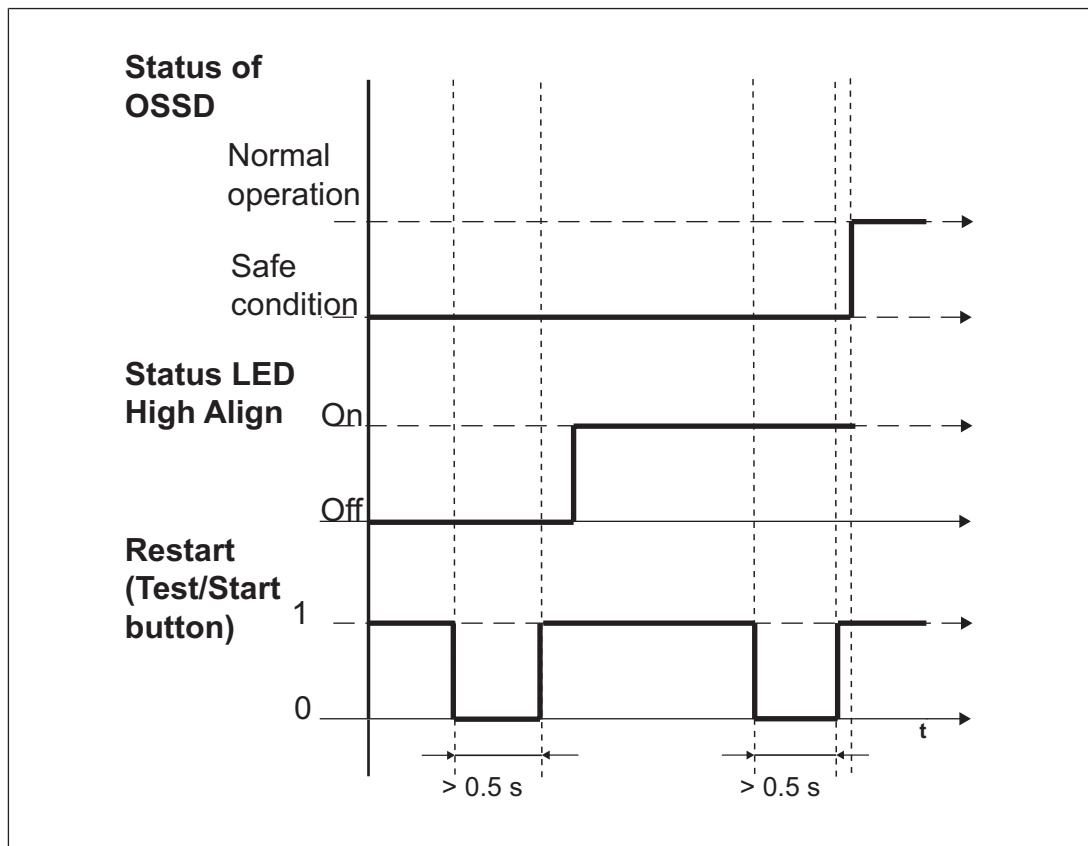

Fig.: Timing diagram for restart in operating mode with restart interlock

The type of restart that will be used is set during commissioning via DIP switches 4 and 8 (see [Setting the functions](#) [42]).

### 4.3 Reset function

In the event of an internal error on the safety light grid, the safety light grid switches to a safe condition and stops the connected machine. In order to restore normal operating conditions, the safety light grid must be reset.

Internal errors are:

- ▶ Malfunction of the outputs or
- ▶ Optical malfunction or
- ▶ Malfunction of the muting display or
- ▶ Incorrect operation of the EDM function.

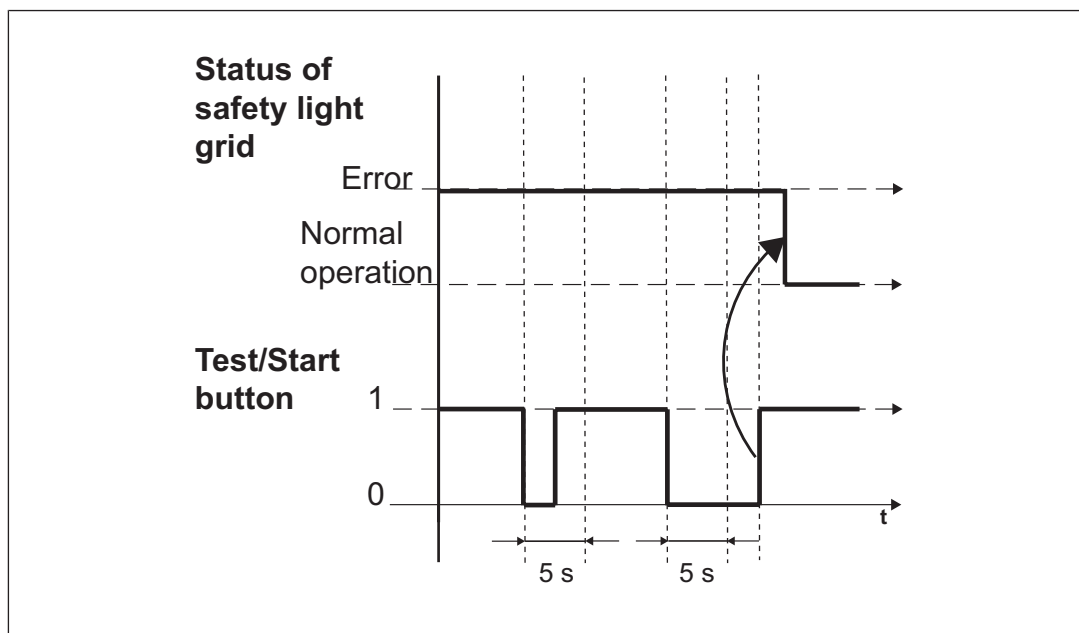

Fig.: Timing diagram - Reset after malfunction

## 4.4

### EDM

Contactors outside the safety light grid can be monitored (External Device Monitoring = EDM, also known as feedback loop monitoring).

EDM only needs to be activated if the contactors are controlled directly.

A test is performed to see that the N/C contacts switch if the state of the OSSD changes and so is used to monitor and detect malfunctions on the contactors. If a malfunction is detected, the safety light grid switches to a safe condition and stops the connected machine. This check is carried out each time the OSSD is triggered and before restarting.

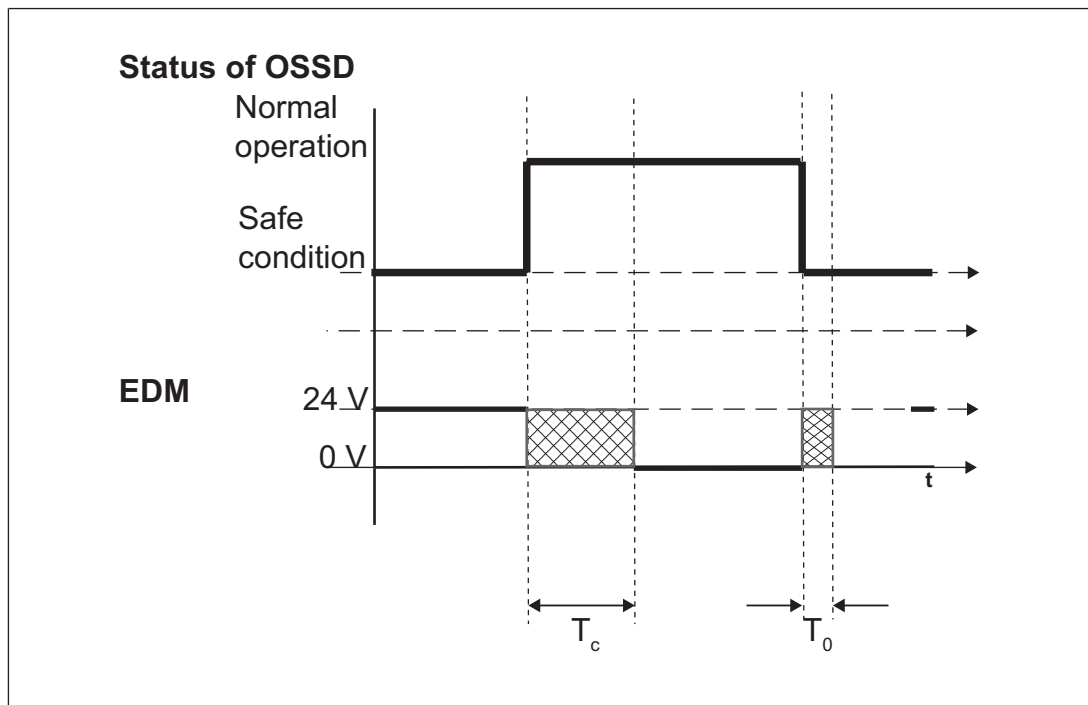

Fig.: Timing diagram EDM

$T_c \geq 350 \text{ ms}$	After the OSSD outputs are switched on, the EDM circuit must open within 350ms
$T_0 \geq 100 \text{ ms}$	After the OSSD outputs are switched off, the EDM circuit must close within 100ms

Use control elements whose dynamics match the times stated at  $T_c$  and  $T_0$ .

The function is controlled via DIP switches 3 and 7 (see [Setting the functions](#) [42]).

## 4.5 Muting

If the safety light grid is equipped with separate muting sensors, the muting function can be used to overwrite the safety light grid during operation, subject to special operating conditions.

- ▶ Example of a special operating condition:
  - Material is transported into the protected field on a conveyor and the safety light grid is overridden for the time it takes the material to pass through

Muting proves to be particularly suitable when, under certain operating conditions, an object is permitted to pass through the danger zone but a person is not.

The following diagrams illustrate application examples for the three product types.

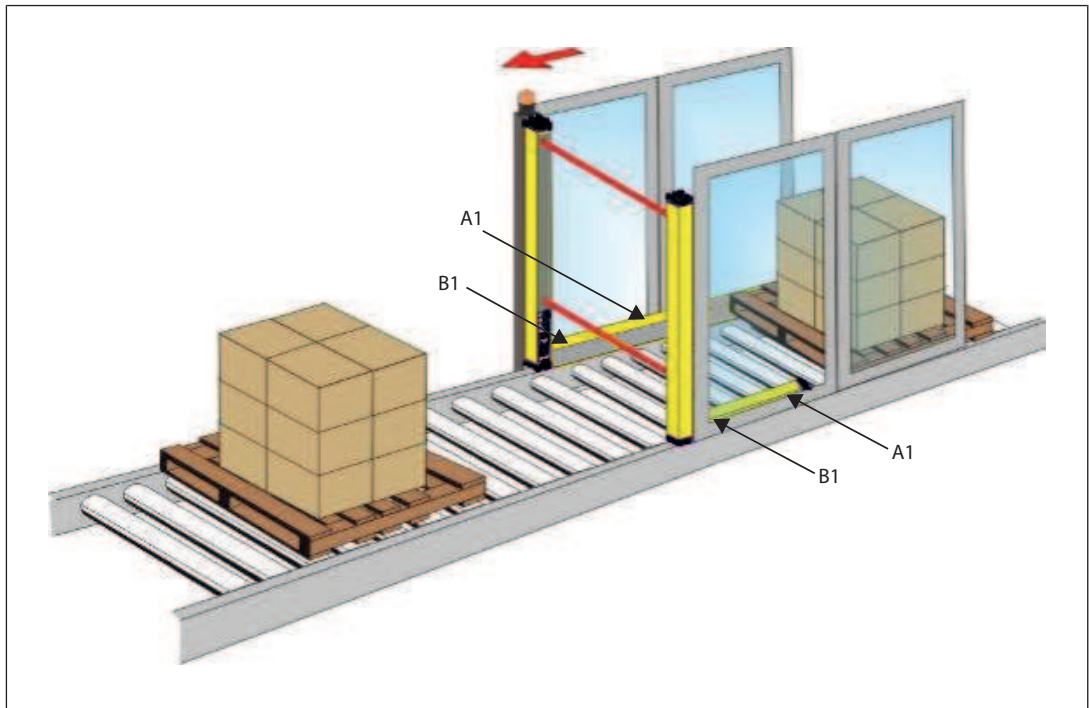

Fig.: Muting in one direction: Expansion with L-muting set

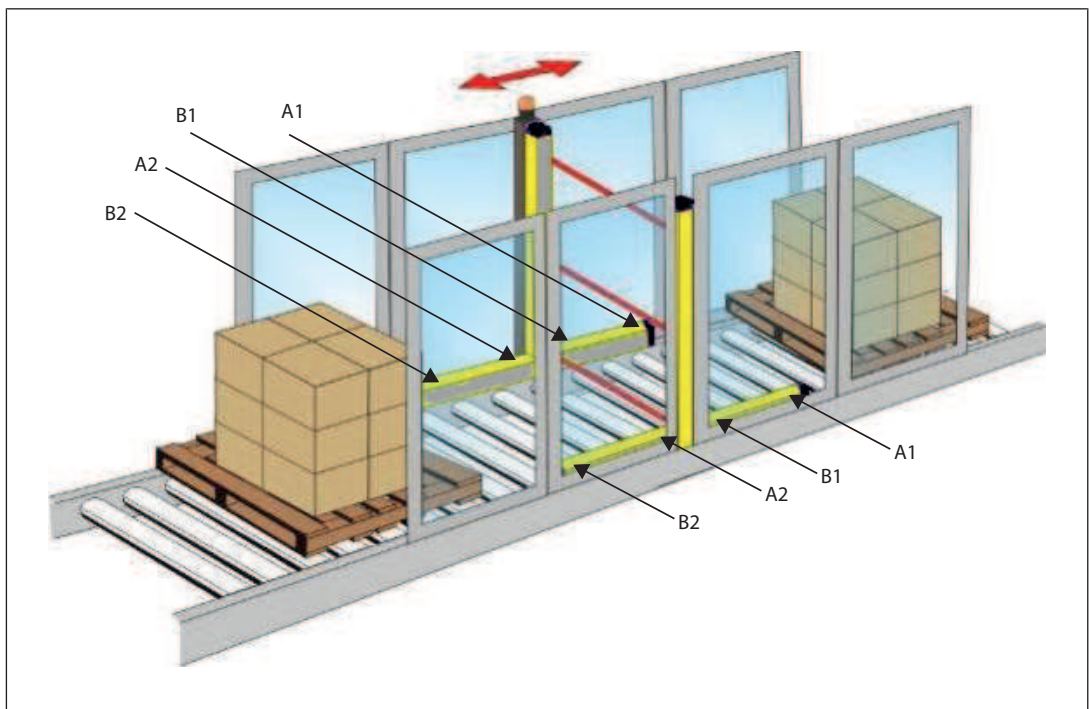

Fig.: Muting in two directions: Expansion with T-muting set

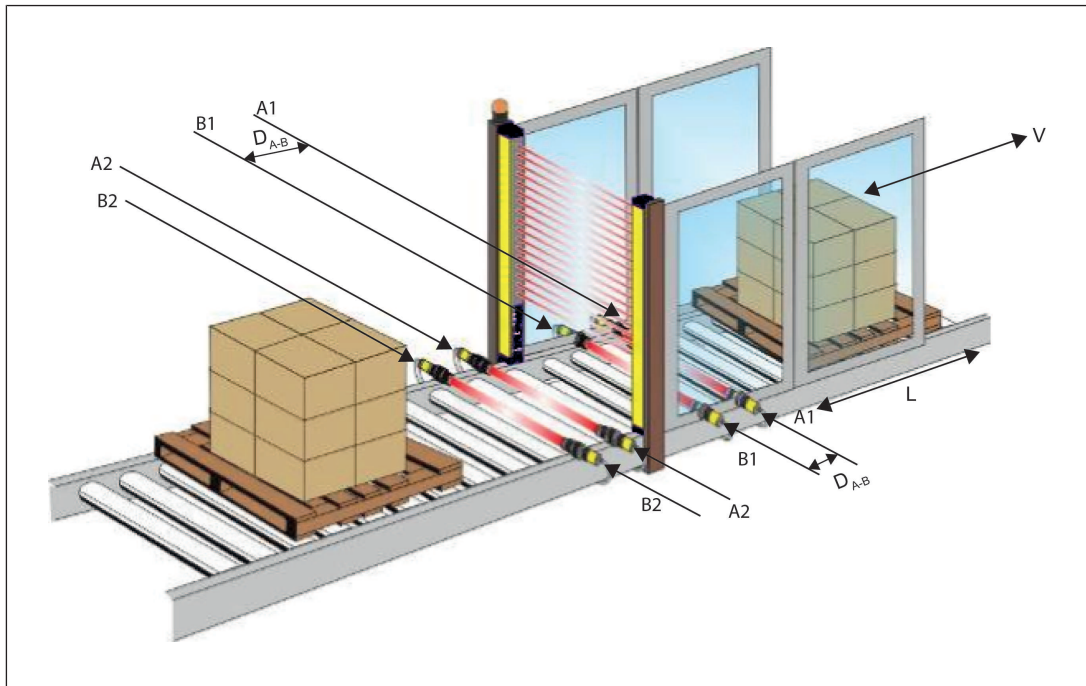

Fig.: Muting in two directions: Expansion with external muting sensors



#### CAUTION!

If the safety light grid is in a muting status, the OSSDs continue to be switched on

The connected machine remains in operation and so represents a potential hazard.

- Prevent access to the danger zone during muting.

Identification of the conveyed material (pallets, vehicles...) must be guaranteed with all

- ▶ Material dimensions and
- ▶ Conveyor speeds

that are intended to arise during operation.

Different conveyor speeds in the area of the safety light grid should be prevented.

### 4.5.1 Technical implementation

The safety light grid has two inputs, Muting 1 and Muting 2, to activate the muting function.

The muting sensors are connected to these inputs. The muting sensors must be positioned and installed at a right angle to the receiver and transmitter (see [Installation and wiring](#) [ 35]).

- ▶ The muting status occurs
  - when the first sensor and the second sensor detect a conveyed material simultaneously or
  - when the first sensor has detected a conveyed material and the second sensor also detects it max. 4 s afterwards.

**CAUTION!**

Transport speed too low

If the transport speed is too low, the conveyed material will not trigger a muting status.

The transport speed should be selected so that the conveyed material passes the second sensor within a max. 4 s of it being detected by the first sensor.

**CAUTION!**

Ending the muting status

Use a mechanical barrier (see diagram) to prevent access to the danger zone once muting is ended.

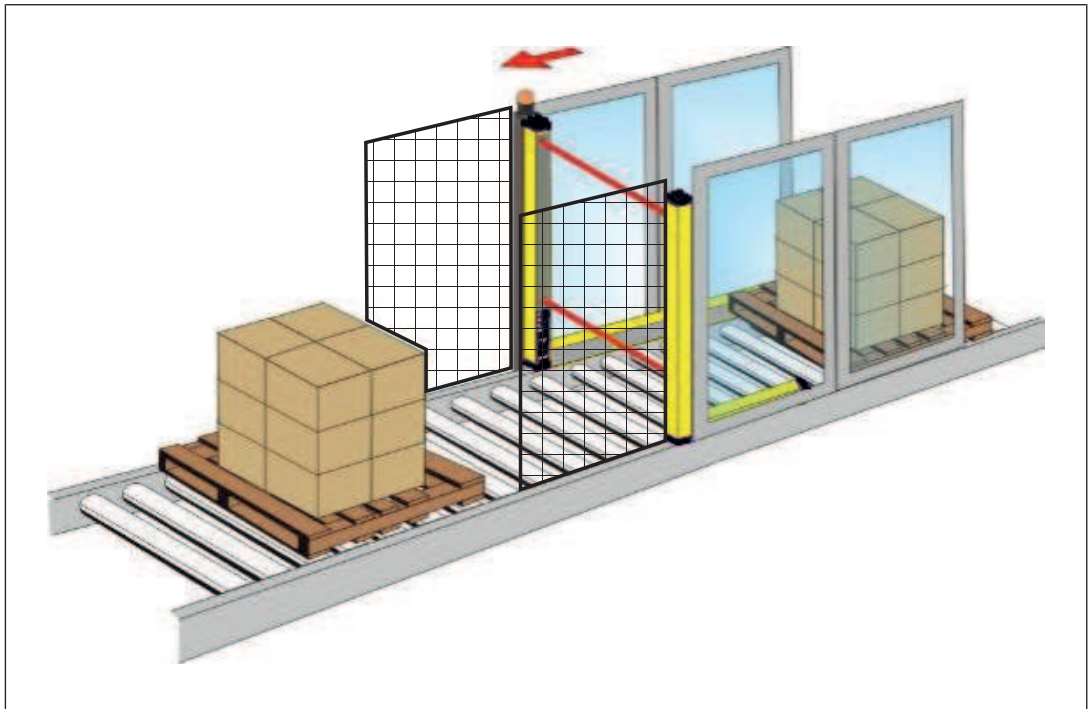

Fig.: Application for muting in one direction - Danger zone is safeguarded once muting is ended

- ▶ The muting status is displaying by the muting lamp, which is positioned on the top of the receiver.



- ▶ If the muting lamp is defective, the muting function cannot be activated. Any attempt to activate the function will immediately trigger the safety light grid and instantly switch off the OSSD; the muting lamp fault indicator will also light (see Indicators for fault diagnostics).

- ▶ Muting cannot be activated when the safety light grid is in a safe condition (red LED is lit, protected field is interrupted).

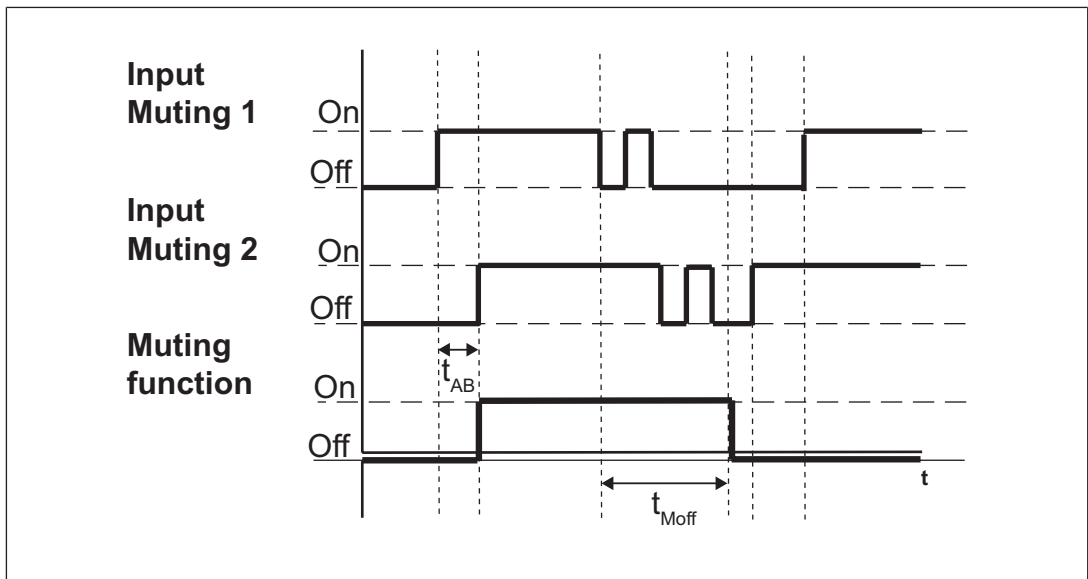

Fig.: Timing diagram for L-type muting

**Legend**

$t_{AB}$ : Time from the activation of the first sensor to the activation of the second sensor, max. 4 s

$t_{Moff}$ : Once this time has elapsed, the muting function switches off automatically, max. 8 s

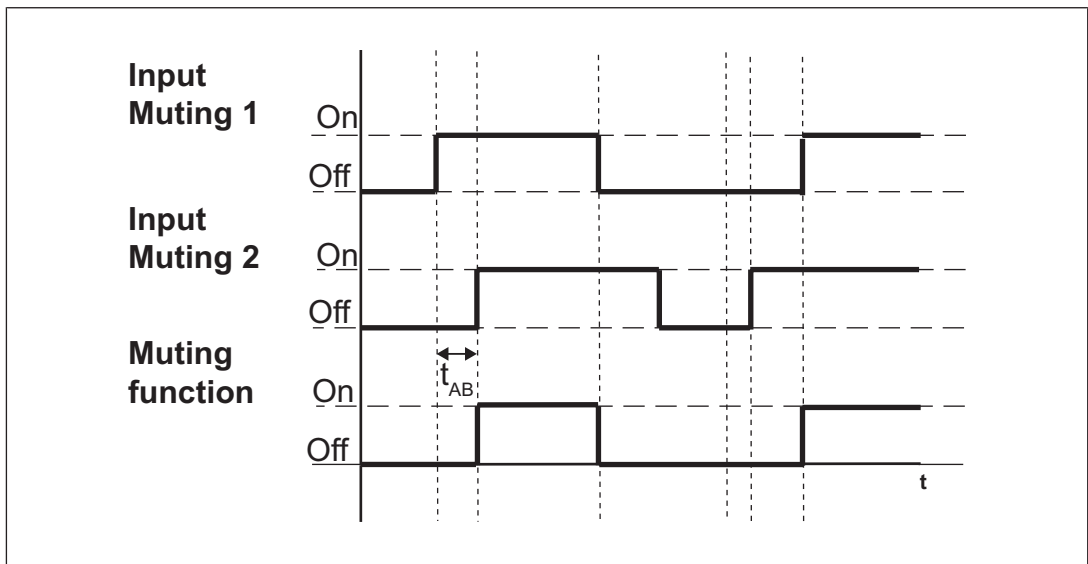
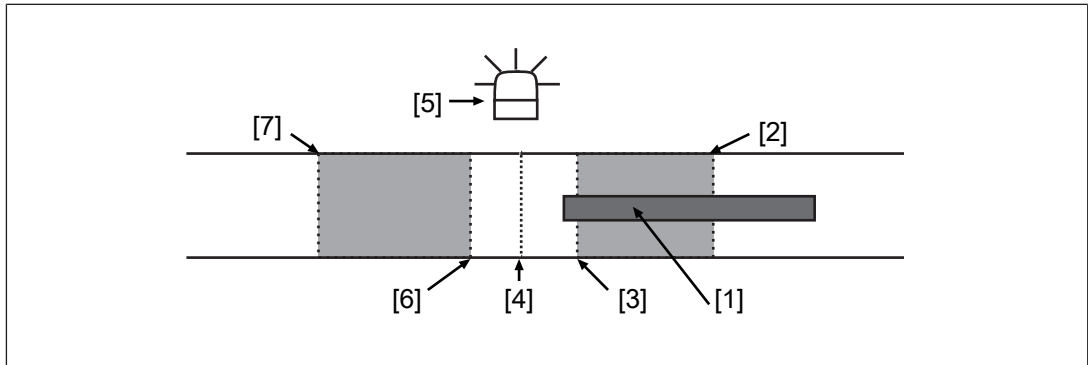

Fig.: Timing diagram for T-type muting

**Legend**

$t_{AB}$ : Time from the activation of the first sensor to the activation of the second sensor, max. 4 s

**Sequence for T-muting cycle when material passes from the right-hand side**



**Legend**

- [1] Conveyed material on conveyor
- [2] First muting sensor on the input side
- [3] Second muting sensor on the input side
- [4] Safety light grid
- [5] Muting lamp
- [6] First muting sensor on the output side
- [7] Second muting sensor on the output side

Phase in the muting cycle	Explanation
	Material has already passed the first muting sensor and is being transported on the conveyor in the direction of the second muting sensor, muting lamp off.
	Material on the conveyor passes the second muting sensor (max. 4 s after the first sensor was passed). Muting lamp flashes, signalling the muting status.
	Material on the conveyor passes the safety light grid and the first muting sensor on the output side, muting lamp flashes, signalling the muting status.
	Material has left the area of the first muting sensor on the output side, muting lamp is off, muting status is ended. The next piece of material arrives at the first muting sensor.
	If material is transported from the left-hand side, the cycle is reversed. The output side becomes the input side and the flow starts with the second muting sensor on the output side.

**4.5.2 Time monitoring - Timeout**

Muting means a temporary suspension of the safety function. For this reason, the muting function must have a time restriction. When the muting sensors are activated and the muting status begins, an internal clock is started. If the muting sensors are still active after 10 minutes (status when delivered), the muting status is cancelled and the safety light grid switches to a safe condition.

Time monitoring for the muting function can be selected via DIP switches 1 and 5 (see [Setting the functions](#) [ 42]).



#### CAUTION!

If time monitoring for the muting function is set to  $\infty$ , the muting function is not cancelled until the muting sensors are no longer active. This setting does not comply with the specifications of EN ISO 61496-1.

**Avoid a situation in which sustained muting is not detected.**

## 4.6 Override

With the override function, a machine can be restarted even though material is interrupting one or more beams.

The reason for this is to clear the danger zone of any material that may have accumulated due to an error in the operating cycle.

For example, if there is a pallet in the protected field and the conveyor can no longer be switched on because the safety light grid is keeping the OSSD switched off (because beams are interrupted), the accumulated material cannot be transported away from the zone.

Activating the override function allows intervention and enables the conveyor to be restarted.

The safety light grid has two connections for override, which are connected via N/O contacts at 24 VDC (Override 1) and 0 VDC (Override 2). Both contacts are closed if the override function is activated.

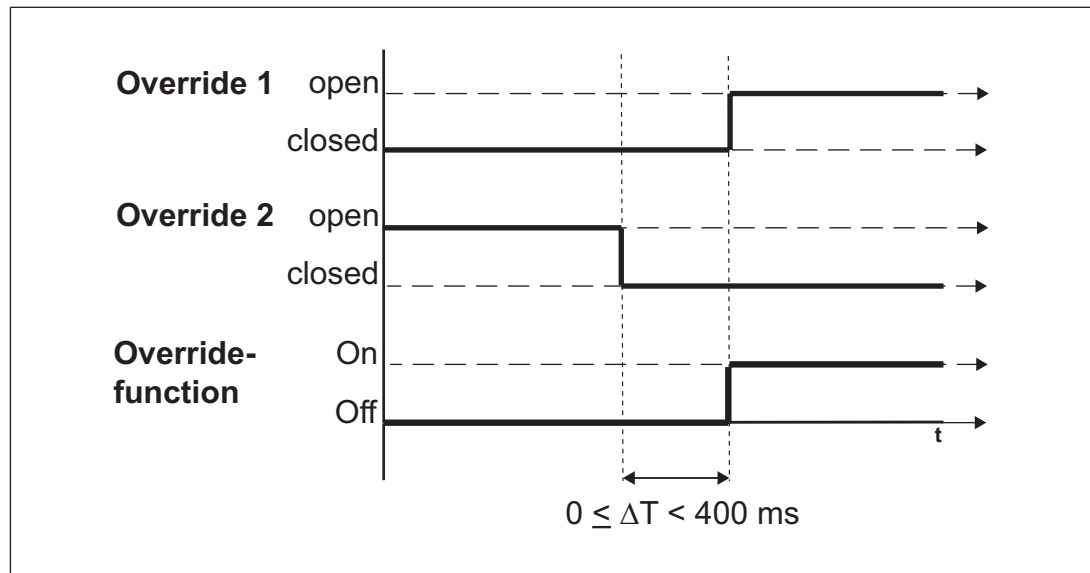

Fig.: Timing diagram for override function

A key or automatic reset button is provided for activation.

Position the key or pushbutton so that when the override function is activated

- ▶ nobody can reach the danger zone and

- ▶ the position of the safety light grid is unchanged.

If a pushbutton is used, the pushbutton must be operated until the protected field is totally clear.

The maximum time there may be between the two inputs Override 1 and 2 on operation is 400 ms.

- ▶ Requirement for activating the override function
  - Safety light grid has triggered and machine has stopped
  - Muting lamp is not defective
  - LED [3] top right flashes yellow:

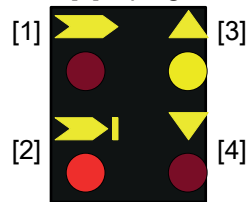

- ▶ Automatic ending of override function

The override function is ended automatically when one of the following conditions is met:

- Muting timeout has elapsed
- The conditions necessary for activation are no longer present.
- Max. duration of override function has elapsed: After 120 s, the safety light grid switches back to its normal operating state.
- No muting sensor is active
- No light beams are interrupted

## 4.7 Test function

The test function can be used to test the safety light grid. The reaction of the safety light grid corresponds to the reaction when a protected field is violated, but can be triggered by pressing the TEST/START button.

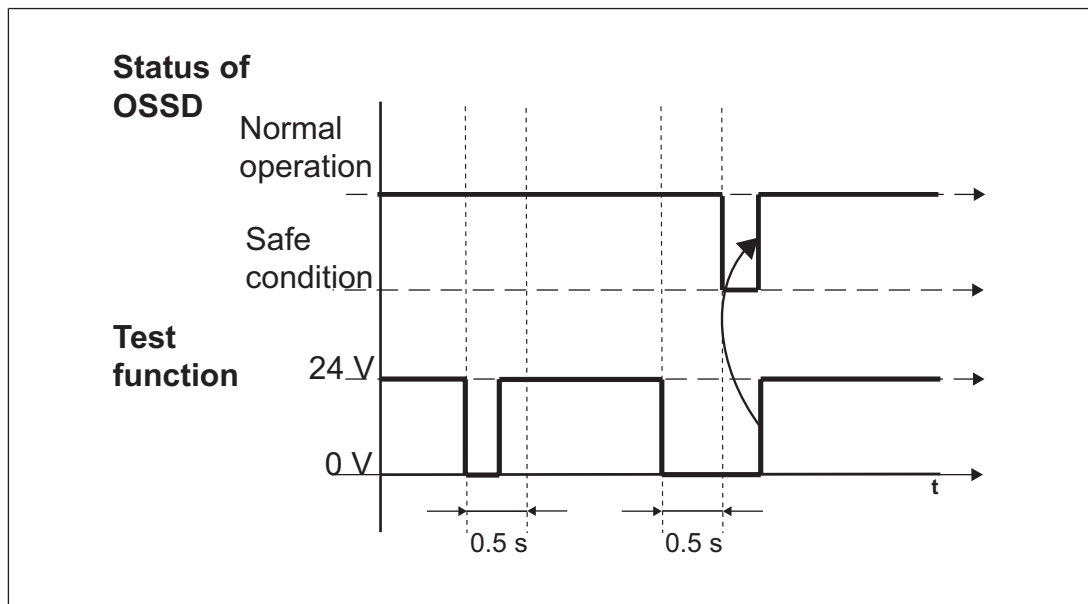

Fig.: Timing diagram for test function

## 4.8 Convert type without muting set to L/T-type

The safety light grids in the PSEN op2B/1 Series series are already capable of processing the data from muting sensors and can be upgraded to L or T-types using the muting sensors available as accessories.

Use the following item numbers for the upgrade:

PSEN op2.1 L-Muting Set	L-muting sensors to retrofit	630 820
PSEN op2.2 T-Muting Set	T-muting sensors to retrofit	630 821
PSEN op muting bracket kit	Mounting bracket for one muting sensor	630 824
PSEN op cable M12 4-p. 0.75m L-muting	Connection cable for L-muting, 4-core, shielded	630 282
PSEN op cableset	Connection cable for T-muting, 4-core, shielded	630 295

## 5 Project configuration

### 5.1 Maintaining the safety distance

The minimum distance of the safety light grid to the hazardous machine component should be such that the operator cannot reach the danger zone until the movement of the hazardous machine part has stopped.

In accordance with the standards

- ▶ EN ISO 13855 (successor to EN 999) and
- ▶ TS-IEC 61496-4-3-CD:2012

this distance depends on four factors:

- ▶ Response time of the safety light grid  
Time between the beams being effectively interrupted and the OSSDs switching off
- ▶ Machine's stopping time  
Time it takes for the hazardous machine movement to effectively stop once the safety light grid switches off (including the reaction time of the connected relay)
- ▶ Approach speed  
Speed at which the object (body) to be detected is nearing the danger zone in mm/s

The general formula for calculating the minimum distance (in accordance with TS-IEC 61496-4-3-CD2:2012) is:

$$S = K * (t_1 + t_2) + C$$

s	Minimum distance in mm, measured from the start of the protected field to the danger source.
K	Approach speed at which the object (body) to be detected is nearing the danger zone in mm/s K = 1600 mm/s when S > 500 mm K = 2000 mm/s when S ≤ 500 mm
t <sub>1</sub>	Response time of the safety light grid in seconds Time it takes for the signal at the OSSD output on the safety light curtain to change once a protected field has been violated
t <sub>2</sub>	Machine's stopping performance in seconds The time required for the machine to stop after the signal at the OSSD output changes
C	850 mm additional distance corresponding to the body resolution of the safety light grid

### 5.2 Ambient conditions

- ▶ Install the safety light grids in an environment that corresponds to the environmental data provided in the [Technical details](#) [ 56].
- ▶ Do not install the safety light grid close to particularly intense and/or flashing light sources; this applies in particular to the receiver.
- ▶ Avoid strong electromagnetic interference when operating the safety light grid.
- ▶ When operating the safety light grid, avoid the development of smoke, mist and dust that would reduce the operating range of the safety light grid.

### 5.3 Distance from reflective surfaces

If there are reflective surfaces close to the beams emitted from the safety light grid (whether from above, below or from the side) passive reflections can mean that an object within the protected field is not detected (see diagram).

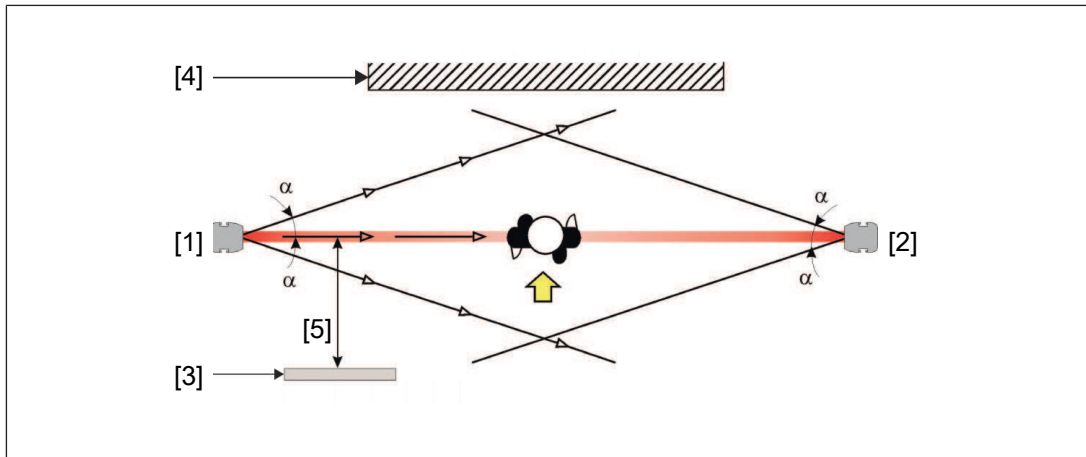

Fig.: Interference to the function of the safety light grid due to reflective surfaces

#### Legende

- [1] Transmitter
- [2] Receiver
- [3] Reflective surface
- [4] Danger zone
- [5] Distance from safety light grid to reflective surface
- $\alpha$  Opening angle of the light beams emitted by the safety light grid

The receiver would detect the reflection from the reflective surface as a secondary beam, even if the main beam is interrupted by an existing object requiring detection.

As a result, the safety light grid must be installed at a minimum distance from reflective surfaces.

The minimum distance depends on two factors:

- ▶ Operating range between transmitter and receiver
- ▶ Maximum opening angle of the light beams emitted by the safety light grid
  - $10^\circ = \pm 5^\circ$  in relation to the optical axis

The formula for calculating the minimum distance  $D_{SR}$  is:

- ▶ Operating range < 3 m: 0.27 m
- ▶ Operating range  $\geq 3$  m:  $0.5 \times D_{OP}$  in m  $\times \tan 2\alpha$

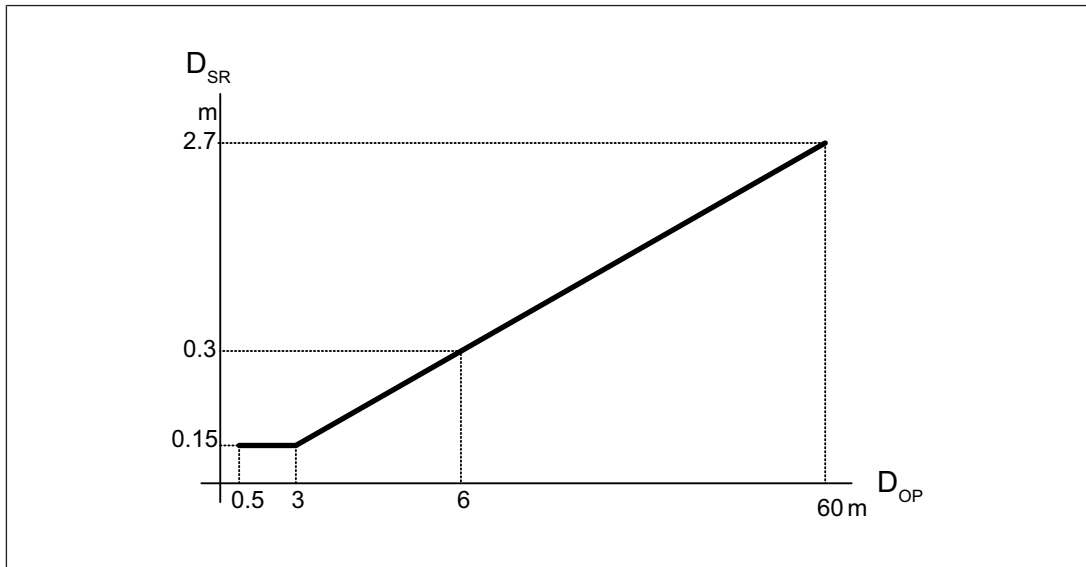

Fig.: Relationship between minimum distance and operating range

#### Legend

$D_{SR}$ : Minimum distance from reflective surfaces in m

$D_{OP}$ : Operating range of the safety light grid in m

## 5.4 Installation of several adjacent safety light grids

If several adjacent safety light grids need to be installed, steps must be taken to ensure that the transmitter on one safety light grid does not interfere with the receiver on another safety light grid.

A layout as shown in the diagram below can cause problems because the light beams from the transmitter on the first safety light grid will influence the receiver on the second safety light grid.

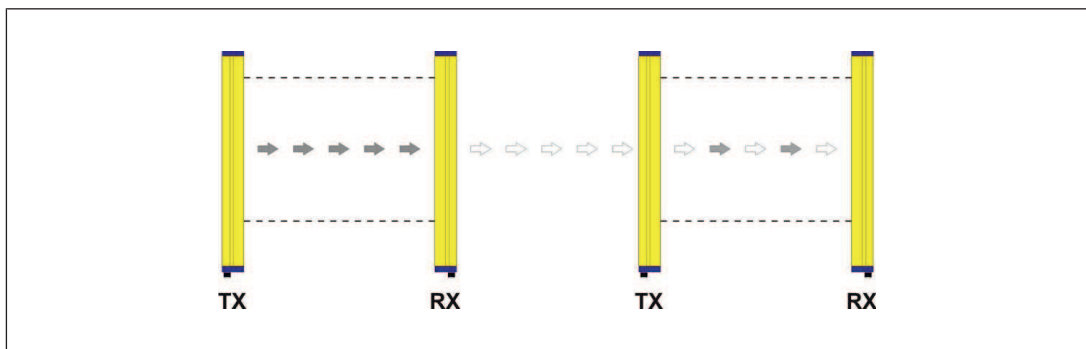

Fig.: Non-permitted layout of two adjacent safety light grids

Positioning of several adjacent safety light grids:

- ▶ Both safety light grids must be oriented in opposite directions **or**
- ▶ An opaque surface must be positioned between two safety light grids.

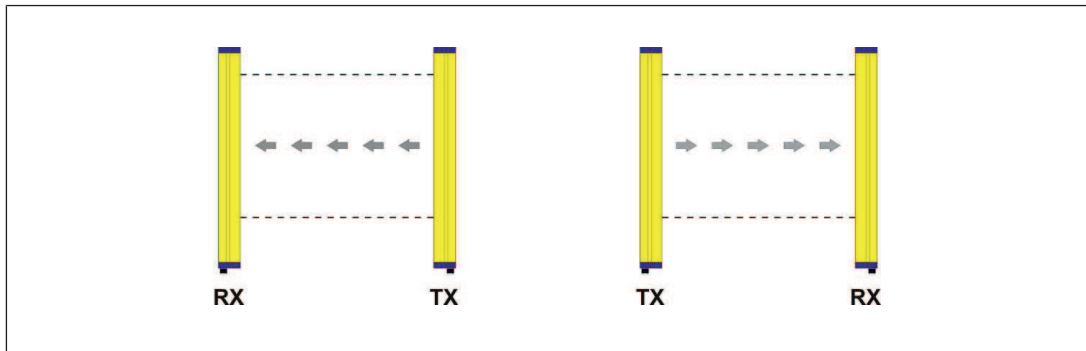

Fig.: Permitted layout of two adjacent safety light grids - opposite orientation

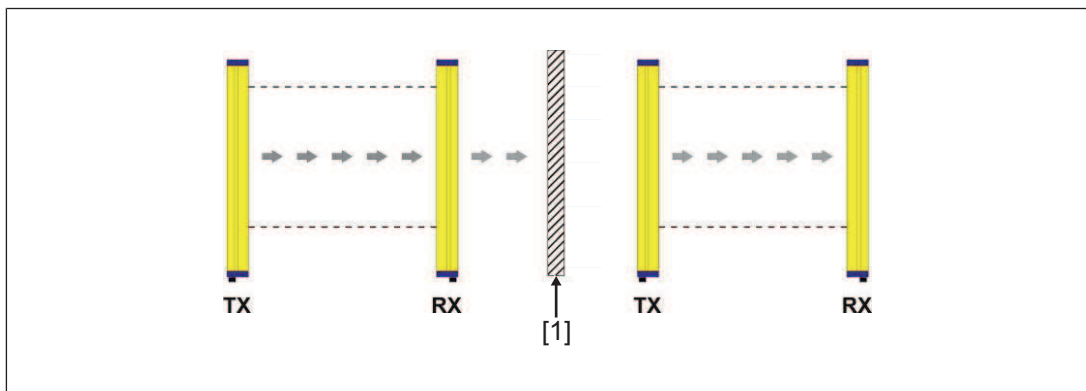

Fig.: Permitted layout of two adjacent safety light grids – opaque surface between the safety light grids

### Legend

[1]: Opaque surface

## 5.5 Use of deviating mirrors

Danger zones with different but adjacent access sides can be monitored using a safety light grid in conjunction with well-positioned deviating mirrors.

The diagram below shows an example solution for monitoring three different access sides using two deviating mirrors. The deviating mirrors must be positioned at an angle of  $45^\circ$  to the beams from the safety light grid.

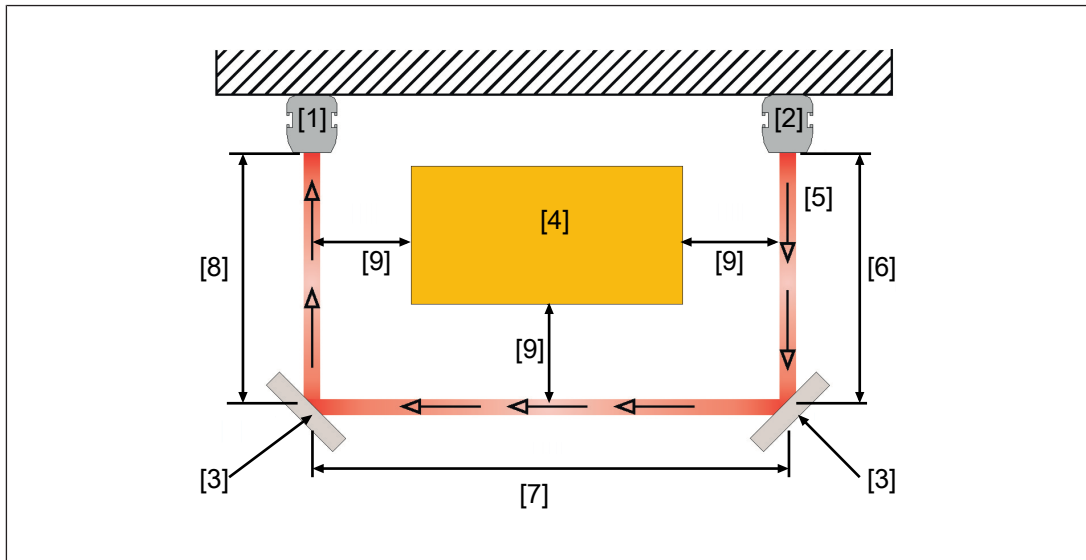

Fig.: Example for using deviating mirrors

### Legende

- [1] Receiver
- [2] Transmitter
- [3] Deviating mirrors
- [4] Danger zone
- [5] Light beams' path from transmitter to receiver
- [6] Distance from transmitter to deviating mirror, corresponds to the maximum effective operating range
- [7] Distance between deviating mirrors, corresponds to the maximum effective operating range, reduced by 15% for each mirror used
- [8] Distance from receiver to deviating mirror, corresponds to the maximum effective operating range
- [9] Minimum safety distance

When using deviating mirrors, please note:

- ▶ Even a minor angular displacement of the mirror can lead to misalignment, adversely affecting or preventing the function of the safety light grid. The [laser pointer](#) [60] available as an accessory should be used for alignment.
- ▶ The minimum safety distance [7] to the danger zone must be maintained for all sections of the beam.
- ▶ Use of a single deviating mirror reduces the effective operating range by about 15%. This percentage increases when two or more deviating mirrors are used (more detailed information is provided in the technical data for the relevant mirror). Please consider this reduction when positioning the safety light grid.
- ▶ You should not use more than three mirrors per device.
- ▶ Any dust or dirt on the mirror's reflective surface will drastically reduce the operating range.

## 5.6 Use of the muting function

Muting means a temporary suspension of the safety function and therefore an increased safety risk. A range of separate precautions must therefore be taken when using the muting function.

- ▶ Muting lamp
  - The muting lamp must be visible from all sides of the work area.
  - The muting lamp must be bright enough inside the work area.
  - The safety light grid must be wired correctly in order for the muting lamp to work correctly (see [Connector pin assignment](#) [ 37]).
- ▶ Use of the muting sensors restricts the operating range of the safety light grid. The achieved operating range must match or exceed the maximum width of the protected field.
  - Operating range of safety light grids with integrated muting sensors = 3 m
  - The operating range of safety light grids with external muting sensors, which use reflective sensors, or external muting sensors, which use transmitter and receiver sensors, depends on the type of the relevant muting sensor (see Technical details of the muting sensor).
- ▶ Prevent access to the danger zone during muting.
- ▶ The muting sensors
  - must detect material and allow it to pass,
  - must detect persons and, when the danger zone is accessed, trigger the OSSD and switch off the connected machine.



### CAUTION!

Transport speed too low

If the transport speed is too low, the conveyed material will not trigger a muting status.

The transport speed should be selected so that the conveyed material passes the second sensor within a max. 4 s of it being detected by the first sensor.

- ▶ Guarantee detection at all travel speeds that are intended to arise during operation.
- ▶ Prevent unintended activation of the muting sensors.
- ▶ Prevent manipulation of the muting sensors through simple means.
- ▶ Inform staff of the
  - hazard potential from the muting function,
  - the absence of protection during muting.
- ▶ Attach a notification sign close to the area protected by the safety light grid, so that it's clearly visible.
- ▶ The sign should indicate that there is no protection when the muting lamp is lit.
- ▶ Please note the following distances and times when installing the safety light grid and using the muting function.

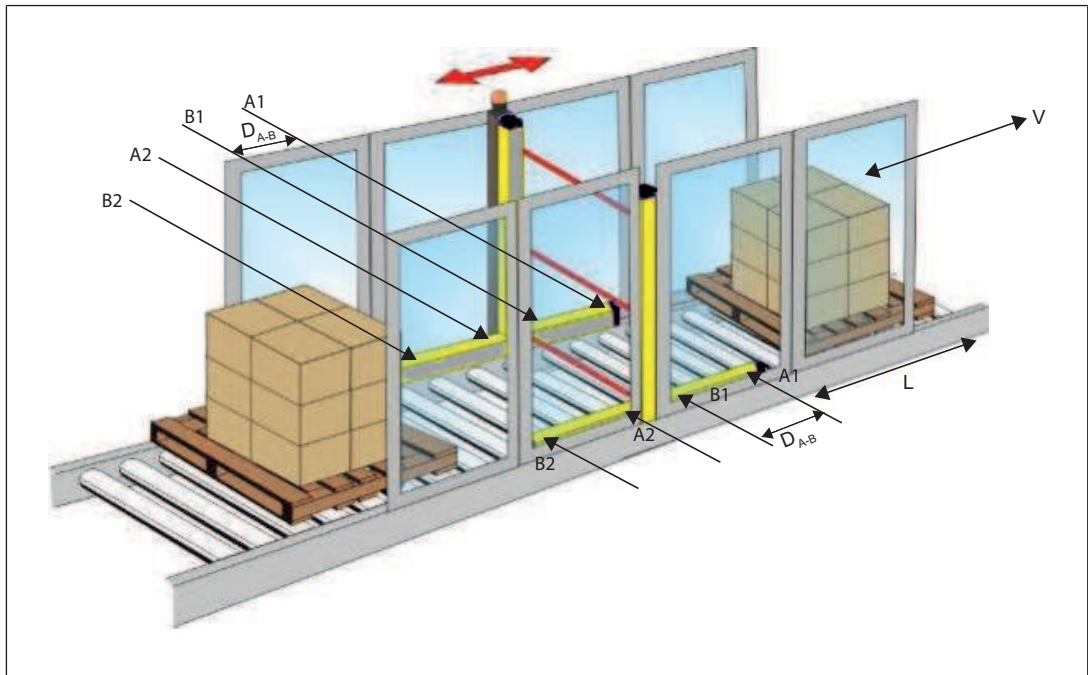

Fig.: Distances between muting sensors in the application example - 4 muting sensors

**Muting in two directions**

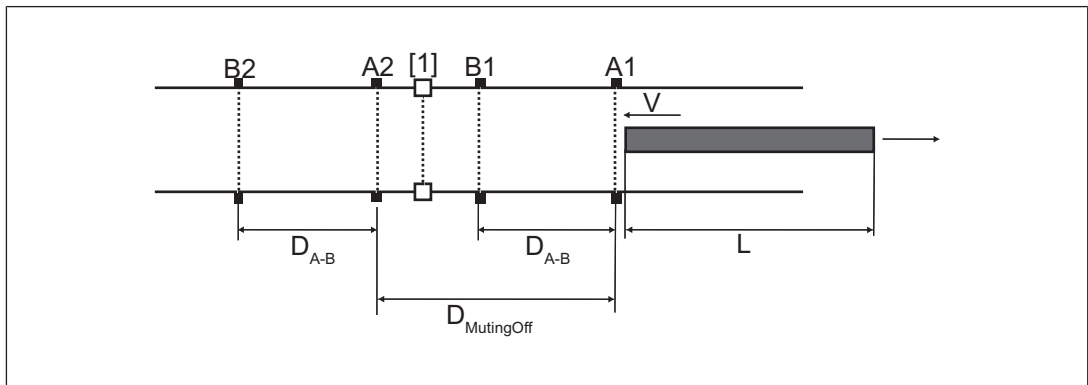

Fig.: Distances between muting sensors - 4 muting sensors

**Legende**

- [1] Safety light grid
- A1 First muting sensor on the input side
- B1 Second muting sensor on the input side
- A2 First muting sensor on the output side
- B2 Second muting sensor on the output side

Icon	Unit	Minimum value	Maximum value	Description
L	cm	$D_{\text{MutingOff}}$		Length of the object that triggers the muting status as it passes the muting sensors
V	cm/s	4.125	250	Speed at which the object is moving
$D_{A-B}$	cm	$< D_{\text{MutingOff}}$	Distance $D_{A-B}$ must be covered in max. 4 s	Distance between the sensors connected to the same muting input A1 and B1, and between A2 and B2
$D_{\text{MutingOff}}$	cm	L		Distance between muting sensor A1 and the position from which the muting function is turned off again, when considering the transport direction from A1 to A2

Distances for muting with 4 sensors

**Muting in one direction**

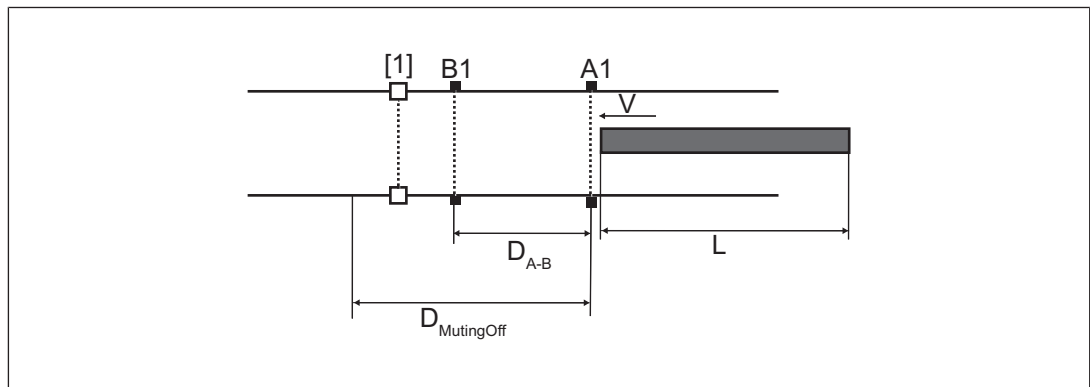

Fig.: Distances between muting sensors - 2 muting sensors

**Legende**

- [1] Safety light grid
- A1 First muting sensor
- B1 Second muting sensor

Icon	Unit	Minimum value	Maximum value	Description
L	cm	$D_{\text{MutingOff}}$		Length of the object that triggers the muting status as it passes the muting sensors
V	cm/s	4.125	250	Speed at which the object is moving
$D_{A-B}$	cm	$< D_{\text{MutingOff}}$	Distance must be covered within 4 s	Distance between the muting sensors A1 and B1

Icon	Unit	Minimum value	Maximum value	Description
$D_{\text{MutingOff}}$	cm	L		Distance between muting sensor A1 and the position from which the muting function is turned off again

Distances for muting with 2 sensors

**Muting in two directions with two muting sensors and cross muting**

When cross muting is used, please note the following:

- ▶ The intersection point of the muting sensors must be behind the safety light grid, within the danger zone (see diagram).
- ▶ By arranging the muting sensors asymmetrically you ensure that the muting sensors must activate consecutively in order to activate a muting state (see diagram).

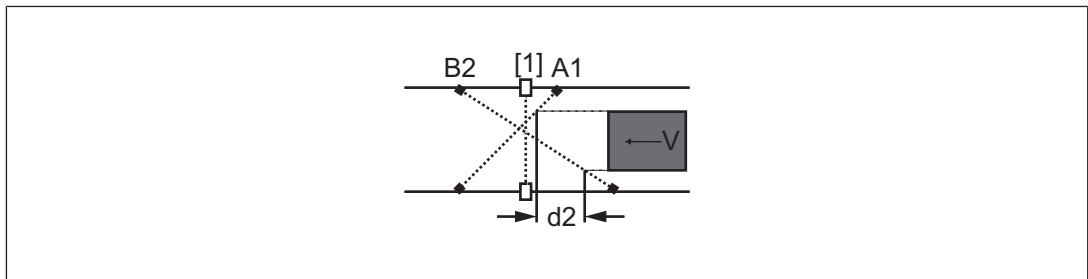

Fig.: Distances between muting sensors - Cross muting

**Legende**

- [1] Safety light grid
- A1 First muting sensor on the input side
- B1 Second muting sensor on the input side

Display	Unit	Minimum value	Maximum value	Description
d2	cm		Distance must be covered within 4 s	Distance that the object covers from the first muting sensor A1 to the second muting sensor B2
$D_{\text{MutingOff}}$	cm	L		Distance between activation of the muting function and the position from which the muting function is switched off again

Distances for cross muting with 2 sensors

## 6 Installation and wiring

Please note the following when affixing the transmitter and receiver:

- ▶ The units' optical surfaces must be arranged so that they are facing each other.
- ▶ The connector sides of both units must be positioned on the same side and at the same height.
- ▶ The distance between the units must be within the operating range of the relevant unit (see [Technical details](#) [ 56]).

### 6.1 Attach safety light grid without muting sensors to mounting surface

#### Procedure

Attach the safety light grid to the mounting surface. Use the two threaded pins supplied to attach the units.

1. Insert the threaded pins into the grooves on both units.
2. Place a mounting bracket on the pins and secure the bracket with the pins.
3. Use screws to provisionally fix the mounting bracket to the mounting surface.
4. Align the safety light grid approximately and then tighten up the screws on the mounting bracket.

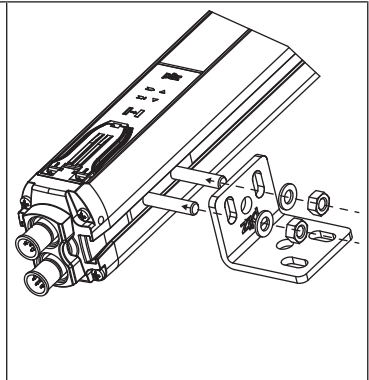

Where vibration is particularly strong

- ▶ threaded pins and
- ▶ mounting bracket

should be used with vibration dampers.

### 6.2 Conversion of safety light grids without muting sensors

- ▶ Allocation of muting sensors to transmitter and receiver:
  - The passive muting sensor PSEN op Reflector must be installed on the transmitter.
  - The active muting sensor PSEN op Reflex must be installed on the receiver.

#### Requirement for installing the muting sensors on the safety light grid:

- ▶ The PSEN op muting bracket kit must be attached to both units of the safety light grid.
- ▶ The safety light grid must already be attached to the mounting surface.

**Procedure**

Check the position of the mounting profile on the safety light grid and slide the mounting profile on both units of the safety light grid along to the correct position of the muting sensor. To do this, loosen the hexagonal screws. Then tighten up the hexagonal screws again.

The mounting profiles should be at the same height.

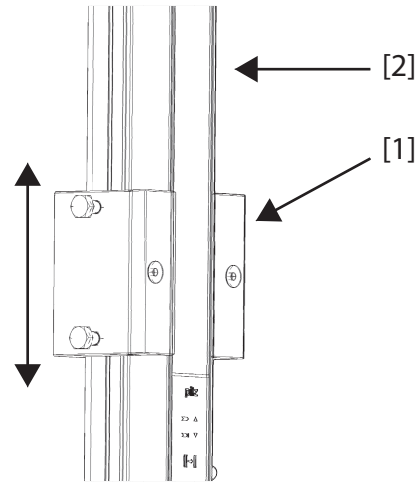

[1] Mounting profile for attaching the muting sensor

[2] Safety light grid on mounting surface

Fix the muting sensor with the small plates to the mounting profile.

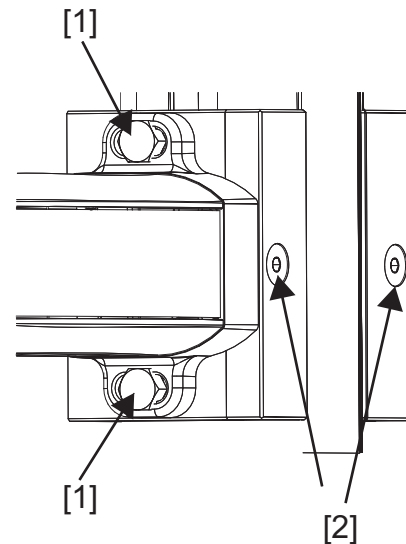

[1] Hexagonal screws for attaching the mounting profile to the safety light grid

[2] Allen screws for attaching the muting sensor to the mounting profile

## 6.3 Installation of external muting sensors

When using external muting sensors, position

- ▶ Sensor B1, with transport in one direction
- ▶ Sensors A2 and B1, with transport in two directions

As closely as possible to the safety light grid (see [Distances between muting sensors in the application example - 4 muting sensors](#) [32]).

## 6.4 Wiring

### 6.4.1 General guidelines

- ▶ Never place connection cables close to or in contact with cables with the following characteristics (motor supply, inverter or similar).
  - High current ratings,
  - Strong current fluctuations.
- ▶ Use separate cables to connect the wires to the OSSDs on different safety light grids.
- ▶ Do not connect contacts OSSD1 and OSSD2 in series or in parallel.
- ▶ Connect the N/C contact on the TEST/START button to the supply voltage on the safety light grid.
- ▶ Connect the N/C contact on the EDM to the supply voltage on the safety light grid.
- ▶ The safety light grid is already equipped with internal filter capacitors. We would advise against using additional external components.

Use the connection cable available as an accessory to wire the safety light grid (see [Order reference for accessories \[📖 59\]](#)).

### 6.4.2 Connector pin assignment

Electrical connections to the transmitter and receiver are made via M12 connectors on both units. These connectors are located on the bottom of the units.

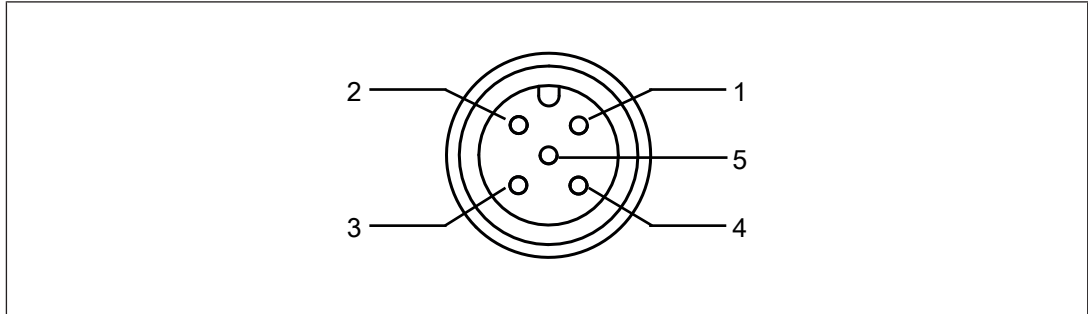

Fig.: 5-pin connector on the receiver to connect muting sensors to the receiver on the safety light grid

PIN	Designation	Description	Cable colour
1	+24 VDC	Supply voltage for external muting sensor	Brown
2	Muting 2	Input signal for second muting sensor	White
3	0 VDC	Supply voltage for external muting sensor	Blue
4	Muting 1	Input signal for first muting sensor	Black
5	n.c.	-	Grey

- ▶ n.c. = not connected

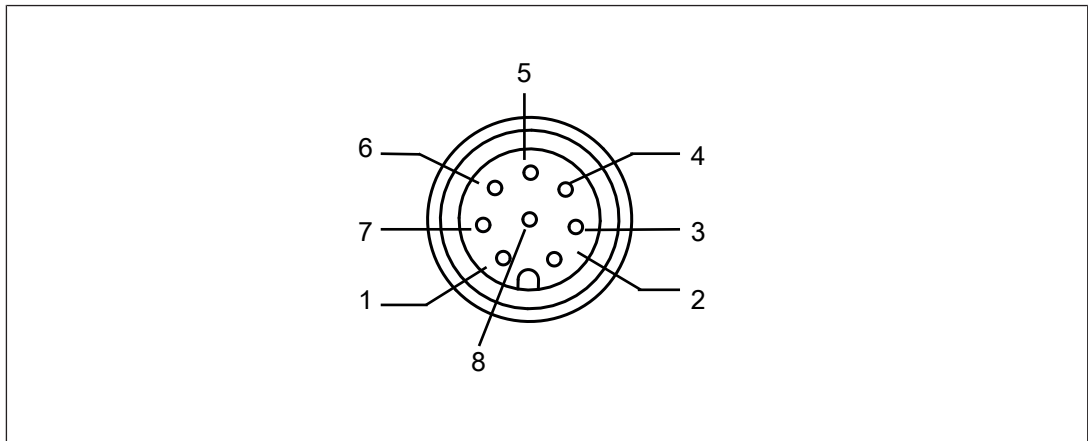

Fig.: 8-pin connector on the receiver to connect receiver to supply voltage and evaluation device

PIN	Designation	Description	Cable colour
1	TEST/RESET	TEST/START button	White
2	+24 VDC	Supply voltage for receiver on the safety light grid	Brown
3	Override 1	N/O contact to override muting sensor input 1	Green
4	EDM	N/C contact for feedback loop monitoring (to ensure that downstream consumers are disconnected)	Yellow
5	OSSD1	Pulsed safety output 1	Grey
6	OSSD2	Pulsed safety output 2	Pink
7	0 VDC	Supply voltage for receiver on the safety light grid	Blue
8	Override 2	N/O contact to override muting sensor input 2	red

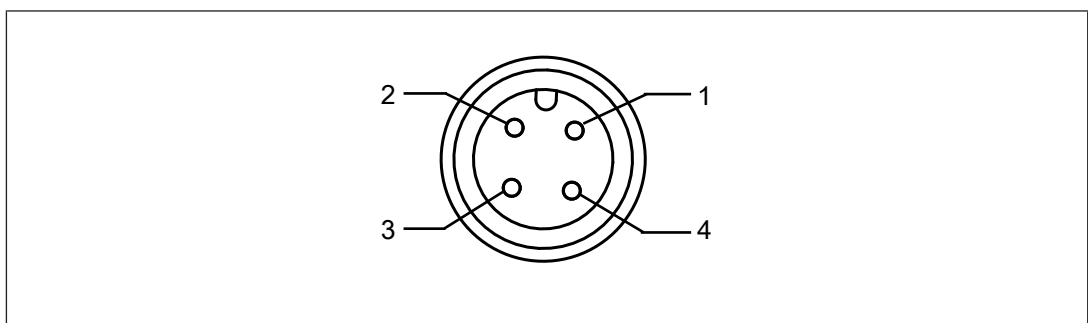

Fig.: 4-pin connector on the transmitter to connect transmitter to supply voltage

PIN	Designation	Description	Cable colour
1	+24 VDC	Supply voltage for transmitter	Brown
2	n.c.	-	White
3	0 VDC	Supply voltage for transmitter	Blue
4	n.c.	-	Black

▶ n.c. = not connected

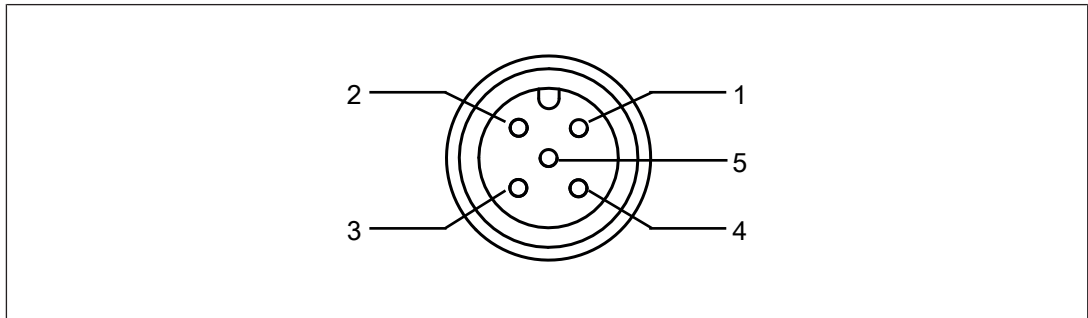

Fig.: 5-pin connector on the transmitter to connect the supply voltage for muting sensors to the transmitter on the safety light grid

PIN	Designation	Description	Cable colour
1	+24 VDC	Supply voltage for external muting sensor	Brown
2	n.c.	-	White
3	0 VDC	Supply voltage for external muting sensor	Blue
4	n.c.	-	Black
5	n.c.	-	Grey

▶ n.c. = not connected

### 6.4.3 TEST/START button

Connect the N/C contact on the TEST/START button to the supply voltage on the safety light grid.

### 6.4.4 EDM

Connect the N/C contact on the EDM to the supply voltage on the safety light grid.

### 6.4.5 Earthing the safety light grid

Attach the earth connection in the drill hole provided on the connector side of the safety light curtain using the screw provided (see diagram).

Identify the earthing contact using the adhesive label provided.

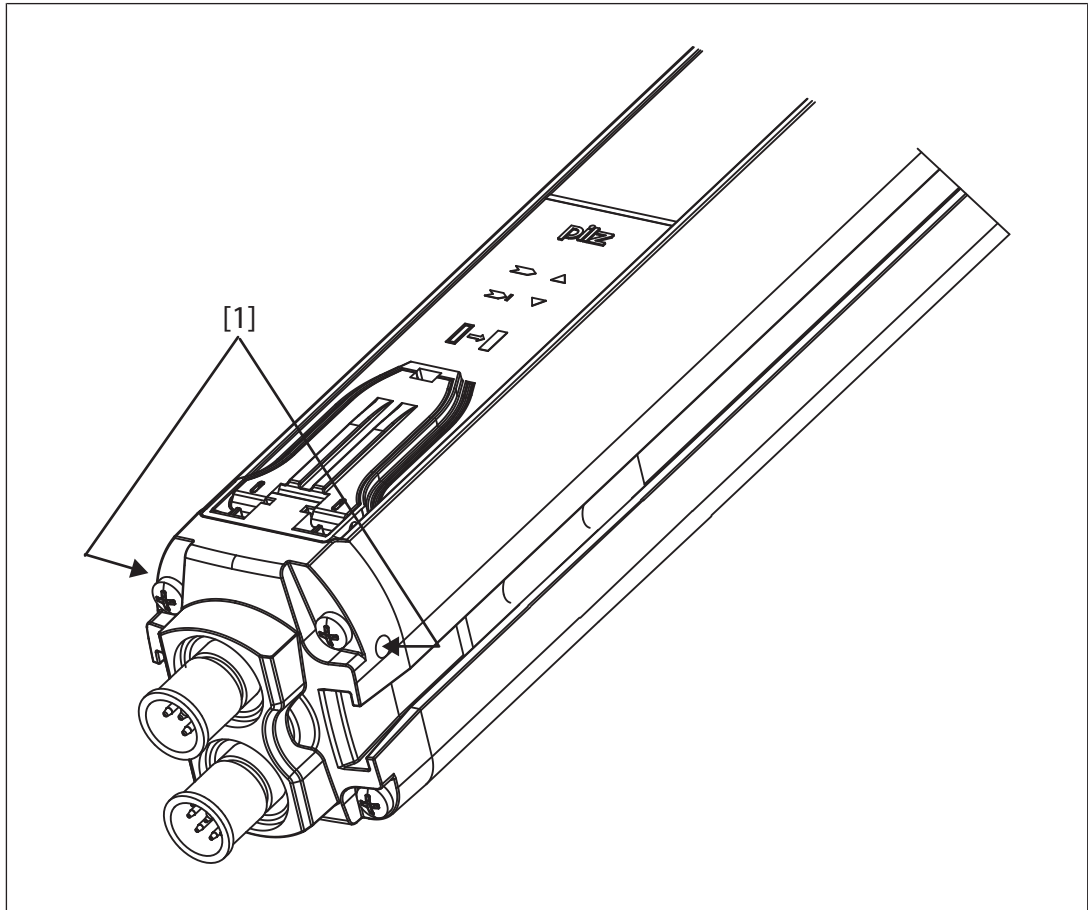

#### Legend:

[1]: Drill holes for earthing screw. The drill holes are on the bottom of the safety light grid, at the same height on the right and left.

### 6.4.6 Connections for muting

Wire the muting sensors using the connection cable provided (see [Order reference for accessories, section on muting accessories](#) [ 60]).

- ▶ For L-muting:  
PSEN op cable M12 4-p. 0.75m L-muting
- ▶ For T-muting and for cross muting:  
PSEN op cableset

The connection cable is used to

- ▶ Connect the muting sensors to the safety light grid
- ▶ Supply voltage to the muting sensors via the safety light grid.

Wire the muting sensors as shown in the following diagrams.

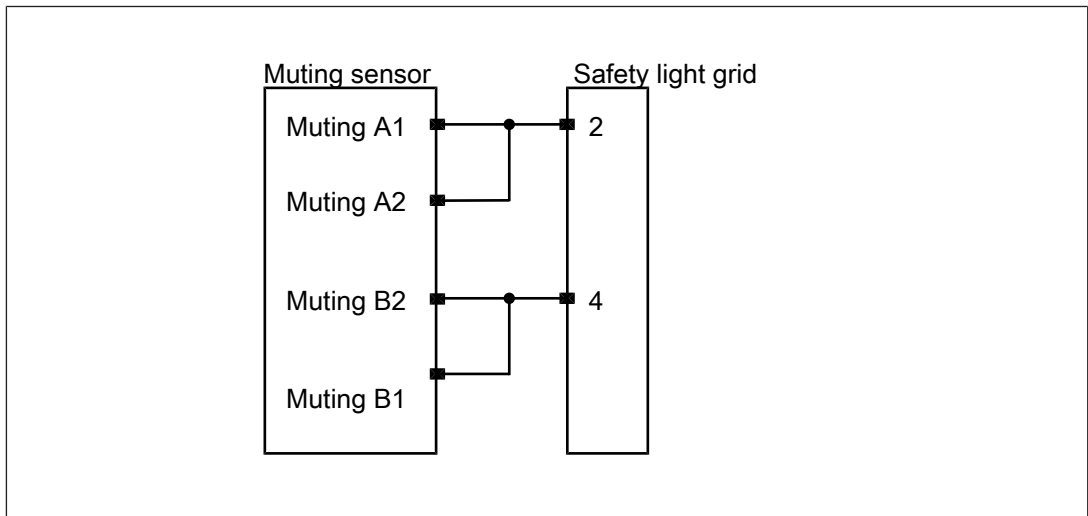

Fig.: Wiring of 4 muting sensors on the receiver's 5-pin connector

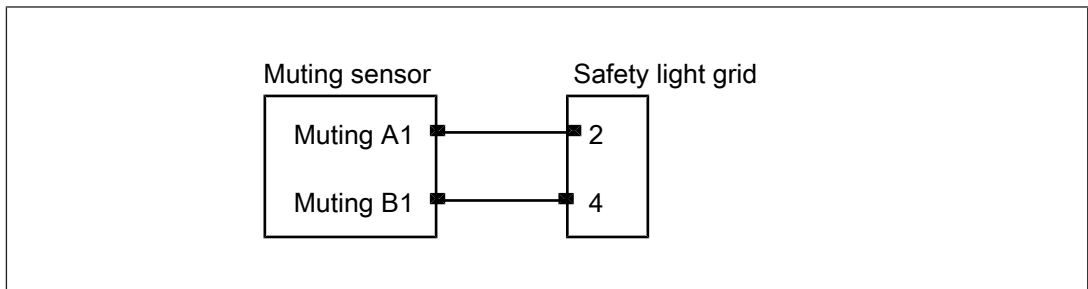

Fig.: Wiring of 2 muting sensors on the receiver's 5-pin connector

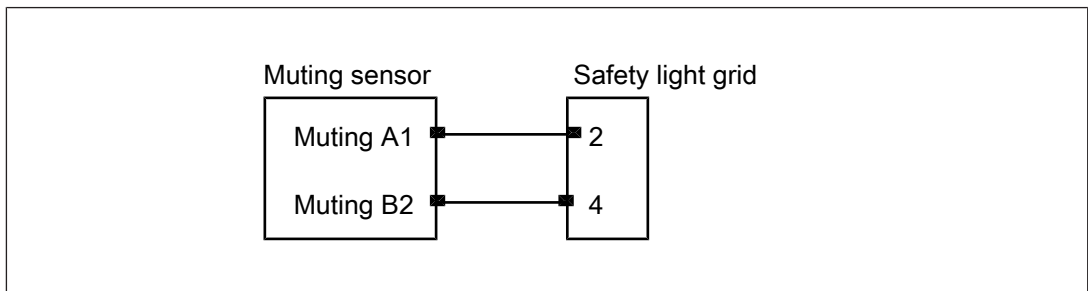

Fig.: Wiring of 2 muting sensors for cross muting on the receiver's 5-pin connector

**Earthing of muting sensors**

Attach the earth connection in the drill hole provided on the side of the muting sensors, using the screw provided. The drill holes for the earthing screw are on the right and left side of the muting sensors, at the same height.

Identify the earthing contact using the adhesive label provided.

**6.4.7 Wiring of external sensors on the safety light grid**

Wire the external muting sensors in the control cabinet in accordance with the details stated under [Connections for muting](#) [40].

## 7 Commissioning

### 7.1 Setting the functions

#### 7.1.1 Open DIP switch cover

The DIP switches must be operated to set the functions of the safety light grid.

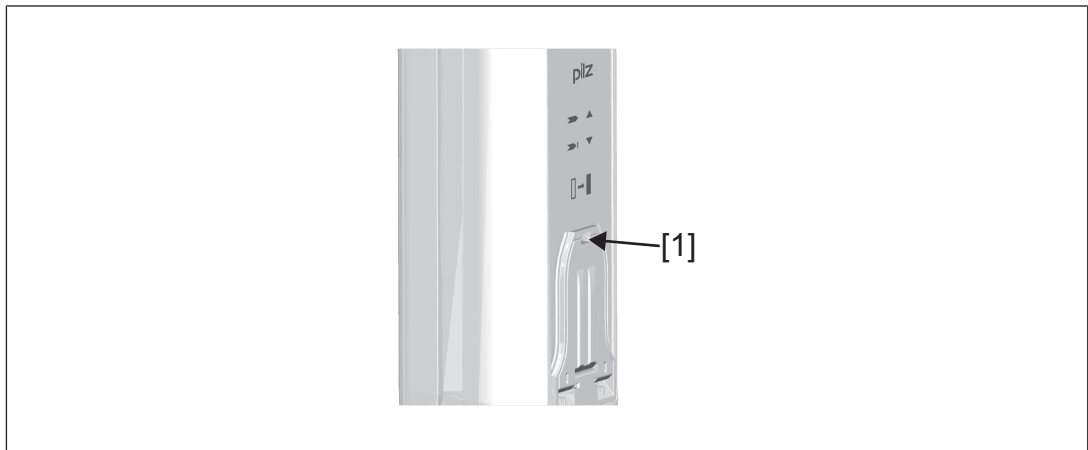

Fig.: Open DIP switch cover

#### Legend:

[1]: Groove on the DIP switch cover

#### Procedure:

1. Insert a thin blade slotted-head screwdriver into the groove on the cover horizontally and at a right angle to the safety light grid (see diagram).
2. Gently press the tip of the screwdriver downwards and lever the cover open.

#### 7.1.2 Activate muting

Muting only needs to be activated in the case of L-muting.

#### Procedure for activating L-muting

1. Switch muting to L-muting on the DIP switch.  
Set DIP switches 2 and 6 to OFF.

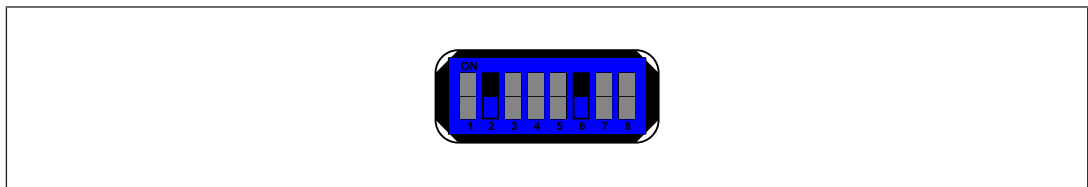



Fig.: DIP switches 2 and 6 in OFF position = L-muting activated

To use muting, the following requirements apply:

- ▶ the muting lamp must not be defective,
- ▶ the muting inputs must be wired correctly (see [Connector pin assignment](#)  37)),
- ▶ the safety light grid must be in normal operation.

If any of these requirements are not met, the safety light grid switches immediately to a safe condition when supply voltage is switched on.

### 7.1.3 Set muting timeout

Time monitoring for the muting function can be set to

- ▶ 10 minutes or
- ▶ to  $\infty$

gestellt werden.

When the unit is delivered, this is already preset to 10 minutes.



#### CAUTION!

If time monitoring for the muting function is set to  $\infty$ , the muting function is not cancelled until the muting sensors are no longer active. This setting does not comply with the specifications of EN ISO 61496-1.

**Avoid a situation in which sustained muting is not detected.**

#### Procedure for setting to $\infty$

Set DIP switches 1 and 5 to OFF.

### 7.1.4 Activate EDM

EDM only needs to be activated if the contactors are controlled directly.

#### Procedure for activating EDM

1. Connect the inputs of the external control elements.  
Connect the inputs to a N/C contact with 24 VDC on the device to be monitored.
2. Activate EDM on the DIP switch.  
Set DIP switches 3 and 7 to OFF.

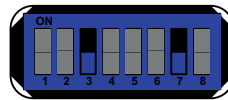

Fig.: DIP switch 3 and 7 in OFF position = EDM activated

### 7.1.5 Restart after unit is triggered

Select how the restart is controlled after the OSSDs have been switched off.

- ▶ Without restart interlock  
Status when delivered
- ▶ With restart interlock  
Set DIP switches 4 and 8 to OFF.

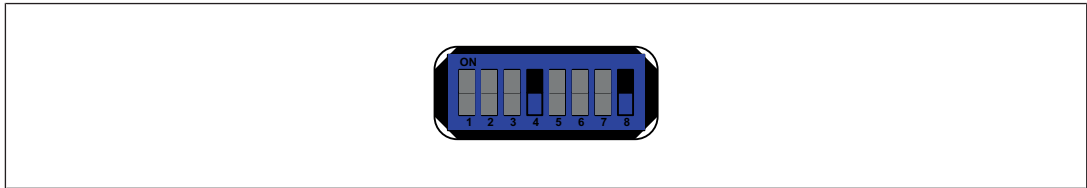

Fig.: DIP switches 4 and 8 in OFF position = With restart interlock

## 7.2 Orientation

### 7.2.1 General guidelines

For the safety light grid to function properly, the transmitter and receiver must be aligned.

Optimum alignment is achieved when the optical axes of the first and last beam from the transmitter coincide with the optical axes of the corresponding elements on the receiver.

The positions of the transmitter and receiver on the safety light grid, and the muting sensors if present, can be modified in accordance with the following diagram.

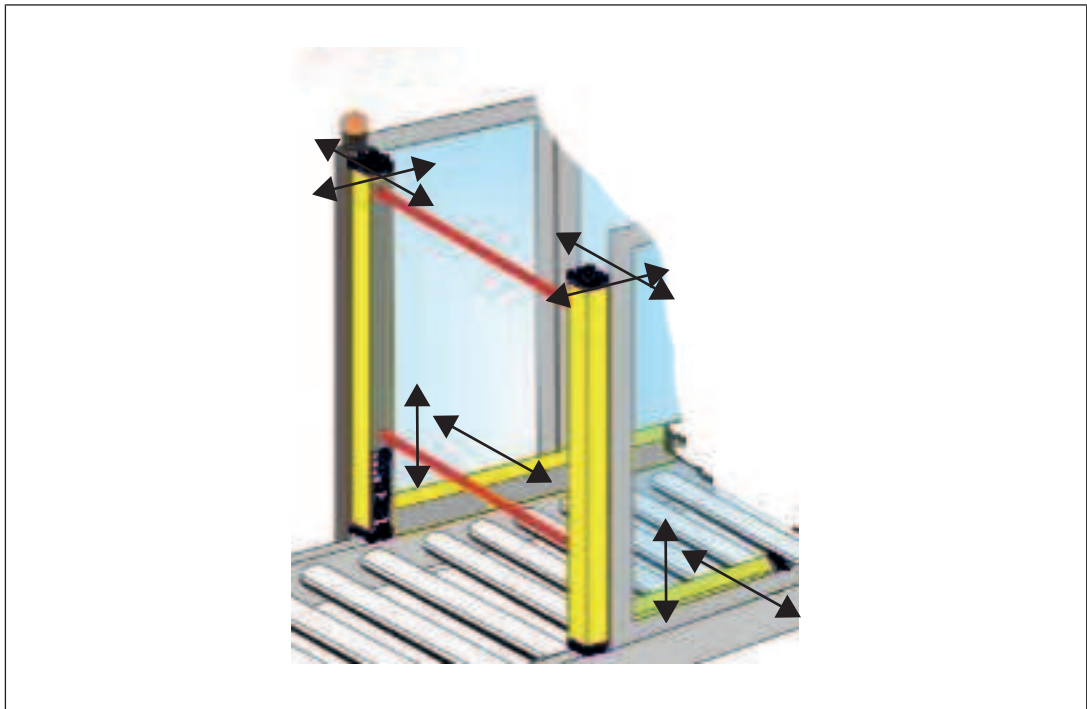

The yellow LEDs High Align [3] and Low Align [4] indicate the status of the alignment.

	<ul style="list-style-type: none"> <li>▶ If the alignment for the upper beam is correct, the LED High Align [3] will light</li> <li>▶ If the alignment for the lower beam is correct, the LED Low Align [4] will light</li> <li>▶ If both beams are aligned correctly and the LEDs are lit, the green LED will also light [1]</li> </ul>
--	--

The alignment of a type without muting set is described under Safety light grid alignment.

When commissioning an L or T-type or external muting sensors, this alignment must also be carried out, followed by alignment of the muting sensors.



#### INFORMATION

For simple, precise alignment of the safety light grid and muting sensors we recommend the use of the laser pointer (order no. 630 340).

Particularly where there are:

- difficult environmental conditions
- large distances between the safety light grid's receiver and transmitter

## 7.2.2 Safety light grid alignment

### Prerequisites

- ▶ Transmitter and receiver are inserted correctly in a suitable place
- ▶ Wiring has been carried out correctly
- ▶ Supply voltage is switched off
- ▶ Protected field is clear

### Procedure

1. Press the TEST/START button and keep the button pressed down.
2. Switch on the supply voltage to the safety light grid.
3. Release the TEST/START button.
4. Prevent anyone from accessing the protected field during the whole time that alignment takes place.
5. Check that the lower, green LED and the yellow LED on the transmitter are lit. The transmitter is ready for operation and is working correctly.
6. Start the alignment if the red LED is lit (incorrect alignment). If the green LED and both yellow LEDs are lit, the alignment is already correct.
  - Hold the receiver steady and align the transmitter so that the lower yellow LED is lit. This means that the lower beam is aligned.
  - Rotate the transmitter around the light axis of the lower lens until the upper yellow LED is also lit, the red LED goes out and the green LED lights.
  - Check that the green LED is permanently lit.
7. Tighten up all the fixing screws.
8. Switch the supply voltage to the safety light grid off and then on again.
9. Check that the green LED on the receiver is lit.
10. Check that the safety light grid operates correctly.
  - If a single light beam is interrupted by an opaque object
    - the green LED must go out,
    - the red LED must light and
    - the safety light grid must switch to a safe condition.

### 7.2.3 Muting sensor alignment

The following steps are only necessary if you are connecting muting sensors to the safety light grid.

1. Check that the safety light grid is aligned correctly and that the safety light grid is in normal operation. The green LED on the receiver, the yellow LED on the transmitter and the two yellow LEDs on the receiver must light.
2. Use the LED to check the alignment of the muting sensors.
3. Modify the position of the muting sensors on the safety light grid until the red LEDs on the sensors go out (see diagram).
  - Vertical alignment of the muting sensors: Undo the hexagonal screws and move the mounting profile upwards.
  - Horizontal alignment of the muting sensors: Loosen the hexagonal screws and move the mounting profile within the slot hole for the hexagonal screws.

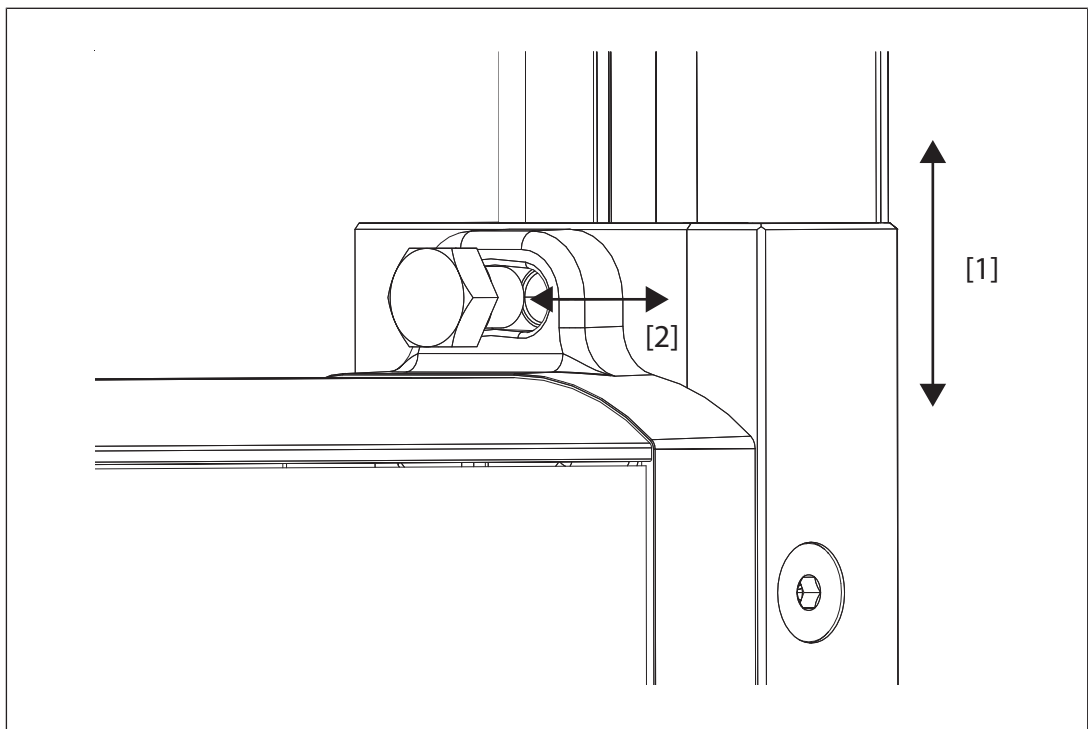

**Legend:**

[1]: Move the muting sensor upwards on the mounting profile for vertical alignment

[2]: Move the muting sensor within the slot hole for horizontal alignment

## 7.2.4 LED support during alignment

Display	LED	Designation	Status	Meaning
	[1]	Normal Operation	Lights green	Transmitter and receiver are correctly aligned and the protected field is clear
	[2]	OSSD	Lights red	Transmitter and receiver are not correctly aligned <b>or</b> protected field is interrupted by an opaque object
	[3]	Restart/Align	Lights yellow	Final upper light beam is aligned with the receiver lens opposite
	[4]	Align	Lights yellow	Final lower light beam is aligned with the receiver lens opposite

LED indicators on the receiver – Meaning during alignment

## 7.3 Checking the safety light grid

Once the safety light grid has been installed and aligned, final inspections must be carried out before it can be put into service.



### INFORMATION

This inspection may only be carried out by qualified personnel.

- ▶ Check that the safety light grid, including any existing muting sensors, are aligned and attached correctly. The red LED should not light up if gentle pressure is applied to the edges of the safety light grid.
- ▶ Check that the safety distance complies with the requirements stated in Maintaining the safety distance.
- ▶ Check that the area between the safety light grid and the hazardous machine component is inaccessible from all sides.
- ▶ Check that the safety light grid cannot be impaired by external light sources.
- ▶ Check that, once switched on, the safety light grid switches to a safe condition if the protected field is accessed.
- ▶ Violate the protected field and check that
  - the OSSDs are switched off,
  - the red LED lights
  - the monitored machine is shut down.
- ▶ Check that the safety light grid's response time and the machine's stopping performance meet the specifications stated under Maintaining the safety distance.
- ▶ If muting sensors are installed:
  - Check that the muting sensors operate correctly. Access the protected field covered by the muting sensors.
    - The muting lamp on the safety light grid must light.

- The red LEDs on the muting sensors must light.
- The OSSDs must be switched off.
- The monitored machine must be shut down.

## 7.4 System connection

This section provides information on how to connect the safety light grid to an evaluation device.

A safety relay from the PNOZsigma series (PNOZ s4, PNOZ s5) can be used as the evaluation device, for example. The wiring is described in the operating instructions for the PNOZsigma device.

## 8 Operation

### 8.1 Status information during operation

The operating state of the safety light grid is displayed using LEDs:

- ▶ four LEDs on the receiver and
- ▶ two LEDs on the transmitter.

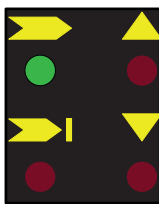
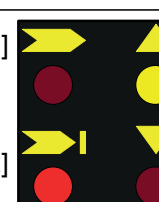
Display	LED	Designation	Status	Meaning
	[1]	Normal Operation	Lights green	Safety light grid in operation, no objects detected
	[2]	OSSD	Lights yellow	Object has been detected, OSSDs are in an OFF state
	[3]	Restart/Align	Lights red	Irrelevant during normal operation ▶ In operating mode with restart interlock: Object has been detected, safety light grid is in a safe condition ▶ During alignment: <a href="#">LED support during alignment [47]</a>
	[4]	Align	Lights yellow	Irrelevant during normal operation ▶ During alignment: <a href="#">LED support during alignment [47]</a>
	[1]	Normal Operation	Off	Override can be performed. Activate the override function and make sure that the protected field is clear.
	[2]	OSSD	Lights red	
	[3]	Restart/Align	Flashes yellow	
	[4]	Align	Off	

LED indicators during normal operation - Receiver

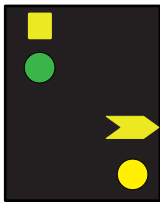
Display	LED	Designation	Status	Meaning
	[1]	Power	Lights green	Supply voltage correct
	[2]	Status	Lights yellow	Safety light grid is transmitting light beams

LED indicators during normal operation - Transmitter

## 8.2 Perform test

### Prerequisites

- ▶ Safety light grid is in operation
- ▶ Correct function of safety light grid

### Procedure

Press the TEST/START button for at least 0.5 seconds.

- ▶ The OSSDs switch off, the red LED lights and the connected machine stops.

## 8.3 Diagnostics and troubleshooting

### 8.3.1 Indicators for fault diagnostics

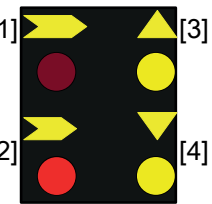
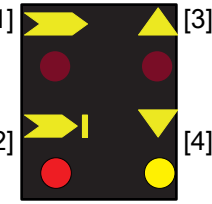
Display	LED	Status	Meaning	Action
	[1]	Off	Functional error on the OSSD	Check the connected OSSDs. Make sure that the load corresponds to the information stated in the <a href="#">Technical details [56]</a> .
	[2]	Flashes red		
	[3]	Flashes yellow		
	[4]	Flashes yellow		
	[1]	Off	Functional error on the connected output signal switching devices (EDM test failed)	Check the connected output signal switching devices. The response times of the output signal switching devices must be compatible with the timing diagram for the safety light grid's test function. Switch the safety light grid off and then on again. If the display is unchanged, swap the external switching device.
	[2]	Flashes red		
	[3]	Off		
	[4]	Flashes yellow		

Display	LED	Status	Meaning	Action
	[1]	Off	Functional error on the safety light grid	Check the correct position of the DIP switches. The positions of the DIP switches must match the intended configuration.
	[2]	Off		
	[3]	Flashes yellow		
	[4]	Flashes yellow		
	[1]	Off	Functional error on override	Check the wiring of the override function. If the display is unchanged, contact Pilz.
	[2]	Lights red		
	[3]	Flashes yellow		
	[4]	Flashes yellow		
	[1]	Off	Optical error	Check the alignment of the transmitter to the receiver. Switch the safety light grid off and then on again. If the display is unchanged, contact Pilz.
	[2]	Off		
	[3]	Off		
	[4]	Flashes yellow		
	[1]	Flashes red	Functional error on muting display	Switch the safety light grid off and then on again. If the display is unchanged, contact Pilz.
	[2]	Off		
	[3]	Flashes green		
	[4]	Flashes yellow		
	[1]	Flashes red	Supply voltage outside the permitted range (see <a href="#">Technical details [56]</a> )	Check that the supply voltage complies with the information stated in the <a href="#">Technical details [56]</a> . Switch the safety light grid off and then on again. If the display is unchanged, contact Pilz.
	[2]	Off		
	[3]	Flashes green		
	[4]	Flashes yellow		

LED indicators in fault condition - Receiver

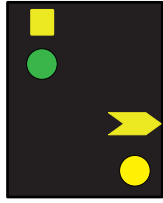
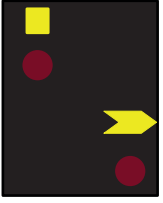
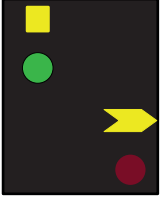
Display	LED	Status	Meaning	Action
 <p>[1] [2]</p>	[1]	Lights green	General transmitter error	Check that the supply voltage complies with the information stated in the <a href="#">Technical details [56]</a> . Switch the safety light grid off and then on again.
	[2]	Flashes yellow		
 <p>[1] [2]</p>	[1]	Off	Supply voltage outside the permitted range (see <a href="#">Technical details [56]</a> )	If the display is unchanged, contact Pilz.
	[2]	Off		
 <p>[1] [2]</p>	[1]	Lights green	Supply voltage outside the permitted range (see <a href="#">Technical details [56]</a> )	
	[2]	Off		

LED indicators in fault condition - Transmitter

### 8.3.2 Perform reset

#### Prerequisites

- ▶ Incorrect function of safety light grid
- ▶ There must be nobody within the danger zone

#### Procedure

Press the TEST/START button for at least 5 seconds and then release it.

- ▶ The OSSDs switch on, the green LED lights and the connected machine starts up.

## 9 Regular checks and maintenance

### 9.1 Checks

#### 9.1.1 Regular checks

The aim of these regular checks is to uncover any changes to the plant/machine, safeguards and ambient conditions.

#### 9.1.2 Daily check

The safety light grid must undergo a function test once a day (e.g. when starting work, after a shift change).



#### INFORMATION

This inspection may only be carried out by qualified personnel.

Check the safety function of the safety light grid as follows:

Violate the protected field. The indicator light unit must change from green to red and the movement causing the hazard must be switched off.

#### 9.1.3 Check after plant/machine modification

Check the safety light grid each time the plant/machine is modified. Changing the safety light grid or swapping safety light grid components should be regarded as a modification. The requirements of the applicable national regulations must be observed **absolutely**.



#### INFORMATION

This inspection may only be carried out by qualified personnel.

The Appendix contains a Checklist which should help you perform the safety check.

### 9.2 Maintenance

Other than cleaning the lens covers, the safety light grids requires no other form of maintenance.



#### CAUTION!

Improper cleaning agents can damage the safety light grid and lead to malfunctions

Moist cotton cloths should be used for cleaning.

Avoid using

- ▶ Alcohol
- ▶ Solvents,
- ▶ Cloths made of wool,
- ▶ Cloths made of synthetic material.

The lens covers should be cleaned during the daily check of the safety light grid.

# 10 Dimensions

## Safety light grid without integrated muting sensors

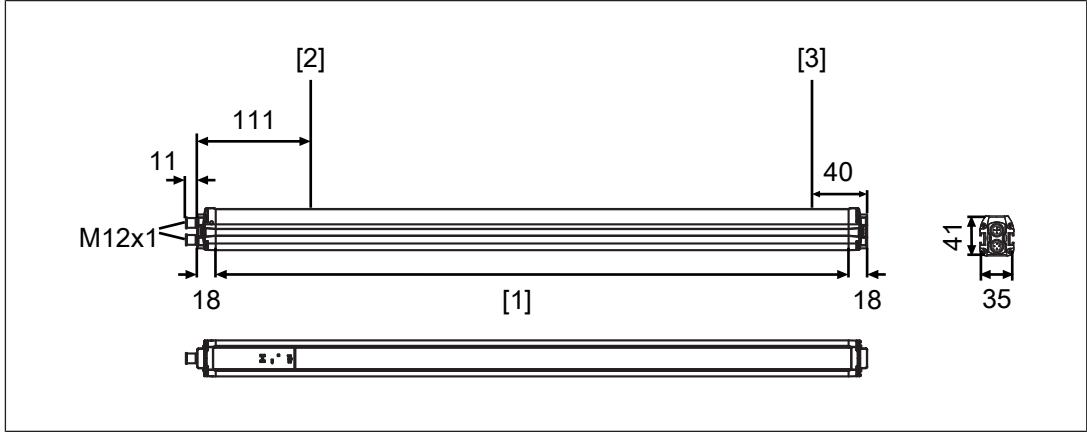

Fig.: Receiver



Fig.: Transmitter

### Legende

- [1] Height of protected field
- [2] Position of first light beam
- [3] Position of last light beam

## 11 Technical details

<b>General</b>	<b>630804</b>	<b>630805</b>
Approvals	CE, TÜV, cULus Listed	CE, TÜV, cULus Listed
Sensor's mode of operation	optical	optical
Height of detection zone	515 mm	815 mm
Operating range	0,5 - 50 m	0,5 - 50 m
Resolution of protected field	515 mm	415 mm
<b>Electrical data</b>	<b>630804</b>	<b>630805</b>
Supply voltage		
Voltage	24 V	24 V
Kind	DC	DC
Max. overall line capacitance C <sub>lmax</sub>	65 nF	65 nF
<b>Optical data</b>	<b>630804</b>	<b>630805</b>
Opening angle	-5 - 5 deg	-5 - 5 deg
Used wavelength range	880 nm	880 nm
<b>Semiconductor outputs</b>	<b>630804</b>	<b>630805</b>
OSSD safety outputs	2	2
Switching current per output	500 mA	500 mA
<b>Times</b>	<b>630804</b>	<b>630805</b>
Response time t <sub>1</sub>	14 ms	14 ms
<b>Environmental data</b>	<b>630804</b>	<b>630805</b>
Ambient temperature		
Temperature range	-10 - 55 °C	-10 - 55 °C
Storage temperature		
Temperature range	-25 - 70 °C	-25 - 70 °C
Climatic suitability		
Humidity	95 % r. h. at 50 °C	95 % r. h. at 50 °C
Condensation during operation	Not permitted	Not permitted
Vibration		
In accordance with the standard	EN 60068-2-6	EN 60068-2-6
Frequency	10 - 55 Hz	10 - 55 Hz
Amplitude	0,35 mm	0,35 mm
Shock stress		
In accordance with the standard	EN 60068-2-29	EN 60068-2-29
Acceleration	10g	10g
Duration	16 ms	16 ms
Airgap creepage		
Pollution degree	2	2
Protection type		
In accordance with the standard	EN 60529	EN 60529
Housing	IP65	IP65

<b>Mechanical data</b>	<b>630804</b>	<b>630805</b>
Material		
Top	<b>Aluminium</b>	<b>Aluminium</b>
Dimensions		
Height	<b>653 mm</b>	<b>953 mm</b>
Width	<b>35 mm</b>	<b>35 mm</b>
Depth	<b>41,2 mm</b>	<b>41,2 mm</b>
Weight	<b>1.910 g</b>	<b>2.610 g</b>
<b>General</b>	<b>630806</b>	<b>630807</b>
Approvals	<b>CE, TÜV, cULus Listed</b>	<b>CE, TÜV, cULus Listed</b>
Sensor's mode of operation	<b>optical</b>	<b>optical</b>
Height of detection zone	<b>915 mm</b>	<b>1.215 mm</b>
Operating range	<b>0,5 - 50 m</b>	<b>0,5 - 50 m</b>
Resolution of protected field	<b>315 mm</b>	<b>415 mm</b>
<b>Electrical data</b>	<b>630806</b>	<b>630807</b>
Supply voltage		
Voltage	<b>24 V</b>	<b>24 V</b>
Kind	<b>DC</b>	<b>DC</b>
Max. overall line capacitance C <sub>lmax</sub>	<b>65 nF</b>	<b>65 nF</b>
<b>Optical data</b>	<b>630806</b>	<b>630807</b>
Opening angle	<b>-5 - 5 deg</b>	<b>-5 - 5 deg</b>
Used wavelength range	<b>880 nm</b>	<b>880 nm</b>
<b>Semiconductor outputs</b>	<b>630806</b>	<b>630807</b>
OSSD safety outputs	<b>2</b>	<b>2</b>
Switching current per output	<b>500 mA</b>	<b>500 mA</b>
<b>Times</b>	<b>630806</b>	<b>630807</b>
Response time t <sub>1</sub>	<b>16 ms</b>	<b>16 ms</b>
<b>Environmental data</b>	<b>630806</b>	<b>630807</b>
Ambient temperature		
Temperature range	<b>-10 - 55 °C</b>	<b>-10 - 55 °C</b>
Storage temperature		
Temperature range	<b>-25 - 70 °C</b>	<b>-25 - 70 °C</b>
Climatic suitability		
Humidity	<b>95 % r. h. at 50 °C</b>	<b>95 % r. h. at 50 °C</b>
Condensation during operation	<b>Not permitted</b>	<b>Not permitted</b>
Vibration		
In accordance with the standard	<b>EN 60068-2-6</b>	<b>EN 60068-2-6</b>
Frequency	<b>10 - 55 Hz</b>	<b>10 - 55 Hz</b>
Amplitude	<b>0,35 mm</b>	<b>0,35 mm</b>
Shock stress		
In accordance with the standard	<b>EN 60068-2-29</b>	<b>EN 60068-2-29</b>
Acceleration	<b>10g</b>	<b>10g</b>
Duration	<b>16 ms</b>	<b>16 ms</b>

Environmental data	630806	630807
Airgap creepage		
Pollution degree	2	2
Protection type		
In accordance with the standard	EN 60529	EN 60529
Housing	IP65	IP65
Mechanical data	630806	630807
Material		
Top	Aluminium	Aluminium
Dimensions		
Height	1.053 mm	1.353 mm
Width	35 mm	35 mm
Depth	41,2 mm	41,2 mm
Weight	4.500 g	5.400 g

### 11.1 Safety characteristic data



**NOTICE**

You must comply with the safety-related characteristic data in order to achieve the required safety level for your plant/machine.

Operating mode	EN ISO 13849-1: 2008 PL	EN ISO 13849-1: 2008 Category	EN 62061 SIL CL	EN 62061 PFH <sub>D</sub> [1/h]	IEC 61511 SIL	IEC 61511 PFD	EN ISO 13849-1: 2008 T <sub>M</sub> [year]
2-ch. OSSD	PL c	Cat. 2	SIL CL 1	1,00E-08	SIL 1	–	20

All the units used within a safety function must be considered when calculating the safety characteristic data.



**INFORMATION**

A safety function's SIL/PL values are **not** identical to the SIL/PL values of the units that are used and may be different. We recommend that you use the PASCAL software tool to calculate the safety function's SIL/PL values.

## 12 Order reference

### 12.1 Order reference for safety light grids

Product type	Features	Order no.
PSEN op2B-2-050/1	Safety light grid with body resolution, protected field height 500 mm	630 804
PSEN op2B-3-080/1	Safety light grid with body resolution, protected field height 800 mm	630 805
PSEN op2B-4-090/1	Safety light grid with body resolution, protected field height 900 mm	630 806
PSEN op2B-4-120/1	Safety light grid with body resolution, protected field height 1200 mm	630 807

### 12.2 Order reference for accessories

#### Safety light grid accessories

Product type	Features	Order no.
PSEN op Protective Column-060/1	Protective column for safety light grid, H = 600 mm	630 950
PSEN op Protective Column-090/1	Protective column for safety light grid, H = 900 mm	630 951
PSEN op Protective Column-120/1	Protective column for safety light grid, H = 1200 mm	630 952
PSEN op Protective Column-165/1	Protective column for safety light grid, H = 1650 mm	630 953
PSEN op Protective Column-190/1	Protective column for safety light grid, H = 1900 mm	630 954
PSEN op Protective Base/1	Floor bracket	630 955
PSEN op Bracket kit antivibration	Vibration damper	630 327
PSEN op Protective Column 2-050/1	Protective column with deviating mirror, H = 500 mm	630 961
PSEN op Protective Column 3-050/1	Protective column with deviating mirror, H = 800 mm	630 962
PSEN op Protective Column 4-090/1	Protective column with deviating mirror, H = 900 mm	630 963
PSEN op Protective Column 4-120/1	Protective column with deviating mirror, H = 1200 mm	630 964
Laser pointer for PSEN 4/2	Laser pointer	630 340
PSEN op cable axial M12 4-pole 3m	Connection cable for light beam devices, 4-pole, unshielded, 3 m	630 300

Product type	Features	Order no.
PSEN op cable axial M12 4-pole 5m	Connection cable for light beam devices, 4-pole, unshielded, 5 m	630 301
PSEN op cable axial M12 4-pole 10m	Connection cable for light beam devices, 4-pole, unshielded, 10 m	630 302
PSEN op cable axial M12 4-pole 30m	Connection cable for light beam devices, 4-pole, unshielded, 30 m	630 296
PSEN op cable axial M12 4-pole 50m	Connection cable for light beam devices, 4-pole, unshielded, 50 m	630 362
PSEN op cable axial M12 5-pole 3m	Connection cable for light beam devices, 5-pole, unshielded, 3 m	630 310
PSEN op cable axial M12 5-pole 5m	Connection cable for light beam devices, 5-pole, unshielded, 5 m	630 311
PSEN op cable angle M12 5-pole 10m	Connection cable for light beam devices, 5-pole, unshielded, 10 m	630 312
PSEN cable M12-5sf 20m	Connection cable for light beam devices, 5-pole, unshielded, 20 m	630 298
PSEN op cable axial M12 5-pole 30m	Connection cable for light beam devices, 5-pole, unshielded, 30 m	630 297
PSEN op cable axial M12 5-pole 50m	Connection cable for light beam devices, 5-pole, unshielded, 50 m	630 364
PSEN op cable axial M12 8-p. shield. 3m	Connection cable for light beam devices, 8-pole, shielded, 3 m	630 313
PSEN op cable axial M12 8-p. shield. 5m	Connection cable for light beam devices, 8-pole, shielded, 5 m	630 314
PSEN op cable axial M12 8-p. shield. 10m	Connection cable for light beam devices, 8-pole, shielded, 10 m	630 315
PSEN op cable axial M12 8-p. shield. 30m	Connection cable for light beam devices, 8-pole, shielded, 30 m	630 328
PSEN op cable axial M12 8-p. shield. 50m	Connection cable for light beam devices, 8-pole, shielded, 50 m	630 368

#### Muting accessories

Product type	Features	Order No.
PSEN op2.3 L-Reflex	Single active muting sensor (without mounting bracket)	630 822
PSEN op2.4 L-Reflector	Single passive muting sensor (without mounting bracket)	630 823
PSEN op3.2 Emitter M12	External muting sensor, transmitter	630 832
PSEN op3.1 Receiver NO/NC M12	External muting sensor, receiver	630 831
PSEN op3.3 Reflex NO/NC M12	External muting sensor (reflex light sensor)	630 830

---

PSEN op2.1 L-Muting Set	L-muting sensors to retrofit	630 820
PSEN op2.2 T-Muting Set	T-muting sensors to retrofit	630 821
PSEN op muting bracket kit	Mounting bracket for one muting sensor	630 824
PSEN op cable M12 4-p. 0.75m L-muting	Connection cable for L-muting, 4-core, shielded	630 282
PSEN op cableset	Connection cable for T-muting, 4-core, shielded	630 295

## 13 Attachment

### 13.1 Check list

Note that the check list is not intended to replace the plant-specific safety analysis required for commissioning/recommissioning, nor the resulting inspections and actions.



#### INFORMATION

Commissioning, recommissioning and regular inspection may only be carried out by qualified personnel.

We recommend that you keep the completed check list and store it with the machine documentation for reference.

No.	Action	OK	NOT OK	Notes
1	<b>Check the category/standards</b>			
	Does the category of the safety light grid match the category required for the plant/machine?			
	Have the standards applicable for the plant/machine been considered?			
2	<b>Environmental conditions for checking the safety light grid</b>			
	Have the technical details been met for all the safety light grid components?			
3	<b>Check access to the danger zone</b> Are all access points to the danger zone safeguarded either by safety light grids or by mechanical safeguards?			
4	<b>Check minimum distance to danger zone</b>			
	Has the minimum distance been calculated in accordance with the applicable standards?			
	Has the calculated minimum distance been maintained at all points?			
5	<b>Check protected field</b>			
	Has the ability to creep underneath the protected field undetected been excluded?			

No.	Action	OK	NOT OK	Notes
6	<b>Check safety light grid</b>			
	Make sure that there are no objects in front of the safety light grid (e.g. trailing cable, crossbeams, struts, covers).			
	Make sure that there are no transparent materials between the monitored protected field and the safety light grid (e.g. glass panel).			
	Are all the mechanical connections on the safety light grid attached correctly?			
	Are all the electrical connections to the safety light grid wired correctly?			
7	<b>Check start/reset interlock</b>			
	Check control device (e.g. PITenable, PIT-jog).			
	Is there a control device to release the start/restart interlock?			
	Is the control device positioned correctly?			
	Is the control device installed and wired correctly?			
8	<b>Check the effectiveness of the safety light grid during the hazardous movement</b> Is the safety light grid effective throughout the whole of the plant/machine's hazardous movement?			
9	<b>Check the output circuitry of the programmable safety and control system</b>			
	Have the outputs that have been defined as OSSDs been incorporated in accordance with the required category?			
	Are the switching elements that are connected to the outputs (e.g. valves, contactors) monitored via feedback loops?			
	Does the wiring of the outputs match the circuit diagram?			
10	<b>Switch on safety light grid</b> When you switch on, is it necessary to operate the control device for the start-up interlock before the plant/machine can start up?			
11	<b>Switch off safety light grid</b> Is the hazardous movement stopped immediately when you switch off?			

No.	Action	OK	NOT OK	Notes
12	<b>Check guard function for protected field of the safety light grid:</b> Violate the protected field at various points: The hazardous movement must be shut down. Check that the start/restart interlock is working correctly.			